

---

# Luminoscope® VISUAL SLA 7

---

## User manual [Latest Version 20260427]





---

# Considerations

---

## Copyright, disclaimer and notes clarification

### Copyright

---

No part of this documentation may be reproduced, stored in a retrieval system, or transmitted in any means, electronic, mechanical, photocopying, recording or otherwise, without the prior written permission of LET Automotive NV.

### Disclaimer

---

Every care has been taken by the staff of LET Automotive NV in the compilation of the data contained herein and in the verification of its accuracy when published, however the content of this manual is subject to change without notice due to factors outside the control of LET Automotive NV and this manual should, therefore, be used as a guide only. For example, the products referred to in this publication are continually improved through further research and development and this may lead to information contained in this manual being altered without notice.

This manual is published and distributed on the basis that LET Automotive NV is not responsible for the results of any actions taken by users of information contained in this manual, nor for any error in or omission from this manual. LET Automotive NV does not accept any responsibility whatsoever for misrepresentation by any person whatsoever of the information contained in this manual and expressly disclaims any liability and responsibility, in respect of claims, losses or damage or any other matter, either direct or consequential arising out of or in relation to the use and reliance, upon any information contained or products referred to in this manual.

### Notes clarification

---

LET Automotive products are manufactured for use according to proper procedures by a qualified operator and only for the purposes described in this manual.

The following icons are displayed to indicate additional information that may have added value to the specific topic or is qualified as a precaution measure. Always pay attention to the included information.



**Warning:** Indicates a potential hazardous situation which, if not taken into account, could result in damage or problematic functioning of the device. In some cases, it could also lead to physical injuries.



**Attention:** Indicates important information of particular interest for an efficient and convenient operation of the product. Not taking this information into account could result in damage on problematic functioning of the device or its intended use.



**Note:** Indicates information of interest for efficient and convenient operation of the product or indicates just additional information on the topic.



# Table of Contents

<b>1 Regulations.....</b>	<b>7</b>
1.1 Safety regulations.....	7
1.2 Danger of localized heating.....	7
1.3 Danger laser beam.....	7
1.4 Environmental regulations.....	8
<b>2 Basic Principles.....</b>	<b>9</b>
2.1 Headlamp criteria.....	9
2.2 Adjusting headlamps.....	9
2.3 Lens Principle.....	11
2.4 Advantages of optical block with lens.....	11
2.5 Image projection.....	12
2.5.1 Standard image projection screen.....	12
2.5.2 UK image projection screen.....	12
2.6 Alignment with the vehicle.....	13
2.7 Positioning in front of the headlamp.....	15
<b>3 Headlamps.....</b>	<b>17</b>
3.1 ECE or European low beam.....	17
3.2 High beam.....	18
3.3 Fog beam.....	19
3.4 SAE or American low beam.....	20
3.5 Japanese low beam.....	21
<b>4 Prerequisites for checking or adjusting.....</b>	<b>23</b>
4.1 Prerequisites for the vehicle.....	23
4.2 Prerequisites for the headlamps.....	23
4.3 Positioning the system.....	23
<b>5 Technical characteristics.....</b>	<b>25</b>
5.1 SLA 7 models.....	25
5.2 Guiding systems.....	28
5.2.1 SLA 7 DR: double rail.....	29
5.2.2 SLA 7 SR: single rail.....	29
5.2.3 SLA 7 NR: no rail.....	30
5.3 Layout.....	30
5.3.1 Front view.....	31
5.3.2 Top view.....	32
5.3.3 Left side view.....	37
5.3.4 Right side view.....	39
5.3.5 Rear view.....	40
5.3.6 Alignment laser.....	41
5.4 Dimensions.....	42
5.4.1 SLA 7 DR.....	42
5.4.2 SLA 7 SR.....	43
5.4.3 SLA 7 NR.....	44
5.5 Datasheet.....	45
<b>6 Operation.....</b>	<b>47</b>

6.1 Test cycle references.....	47
6.1.1 Beam icons.....	47
6.1.2 Left / right vehicle side definition.....	47
6.1.3 Alignment with the vehicle.....	48
6.1.3.1 Alignment laser.....	48
6.1.4 Positioning in front of the headlamp.....	50
6.1.5 Vertical beam target.....	50
6.1.5.1 Movable screen. Standard.....	50
6.1.5.2 Fixed screen. UK.....	51
6.2 Test cycle sequence.....	52
6.2.1 Alignment with the vehicle.....	53
6.2.2 Setting the vertical beam target.....	53
6.2.3 Positioning in front of the headlamp.....	54
6.2.4 Beam measurement.....	55
6.2.4.1 Standard movable screen.....	55
6.2.4.2 Fixed DVSA screen.....	55
<b>7 LIM (Light Intensity Module).....</b>	<b>59</b>
<b>8 Personal notes.....</b>	<b>61</b>

---

# 1 Regulations

---

Read these instructions before using or powering up the Luminoscope® system.

## 1.1 Safety regulations

This headlamp tester complies with the necessary safety regulations.

- Improper use or handling of the appliance can compromise the safety of the operator and the environment, as well as the reliability of the measurement.
- Repairs may only be done by the Service engineers of *LET Automotive*. Inexpert repairs can result in danger to the operator and environment.
- Repairs and/or spare parts exchange may only be done with units which are delivered by *LET Automotive*.

Besides the above-mentioned safety regulations, the following must also be observed:

- Do not put or hang objects on the appliance (tools, clothes, etc.).
- Make sure the wheels of the base are always clean. Obstructions on the rails or wheels can bring the system off-balance during a movement.
- The appliance is not waterproof. Keep it safely out from water spills, soaking or submersion into water and any other liquid.
- The appliance is not shock-proof. Protect it against heavy shocks or impacts. Do not drop or let it fall.

## 1.2 Danger of localized heating

### Warning:



- During the seasons of the year when the sun is very low in the sky, there is a risk of the sun shining directly into the collecting lens of the Luminoscope®, so that the focusing effect which is used to complete the headlights tests may cause focalized overheating inside the machine.
- The generated heating may in extreme cases severely damage the Luminoscope®!
- To avoid any possible damage, it is strongly recommended that the dust/sun cover is used whenever the Luminoscope® is not operational.

## 1.3 Danger laser beam

### Green alignment line laser

The headlamp tester may be equipped with an optional green alignment laser with the following characteristics:



### Warning:

- Laser class 2M, wavelength: 520nm, output power less than 5mW
- Staring into the laser can lead to severe damage!

- Do not stare into the laser beam of the laser!



## 1.4 Environmental regulations

### Warning:



- Be aware of the consequences of incorrect waste disposal.
- Incorrect disposal of recoverable materials may negatively impact the environment.
- When the service life of the Luminoscope® expires, the appliance should not be discarded with normal household waste. It should be offered for recycling according to the local currently valid regulations instead.

The following materials are used for the main parts of the Luminoscope® SLA 7:

Part	Material
Fresnel lens	Polymethyl methacrylate (PMMA)
Stand	Aluminium
Optical block	Steel
Base	Steel
Alignment laser	ABS case, aluminum mounting and steel shaft
Battery in alignment laser	2x LR6 (AA) standard single-cell, professional use

---

# 2 Basic Principles

---

What follows is a general explanation of the principles involved in the design and use of Luminoscope® devices and their environment.

## 2.1 Headlamp criteria

During an international conference in Vienna in 1958, it was agreed that the headlamps on vehicles should comply with the following criteria:

- A high beam should illuminate the road in front of the vehicle for at least 100 m (300 ft).
- A low beam should illuminate the road in front of the vehicle for at least 40 m (120 ft) without blinding the oncoming vehicles.

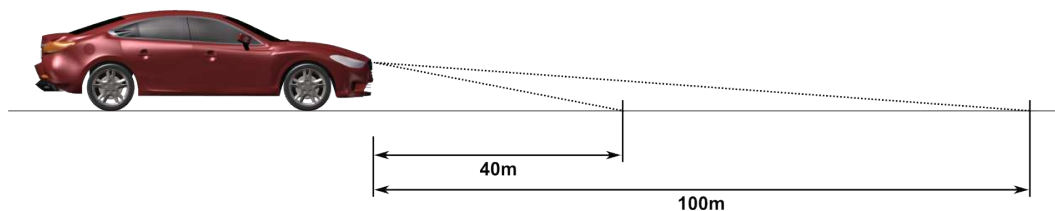

Figure 1: Headlamp criteria

These fundamental criteria don't describe the intensity values, any measuring procedure or how to prevent blinding the oncoming traffic. Therefore, different countries have developed their own standards and technical requirements.

The definition of a headlamp is determined by those standards. In Europe for instance the low beam is described by a "cut off" line which distributes the light beam in a sharp divided light and dark zone, while a low beam in America has to have minimal and maximal intensities in a number of predefined points.

## 2.2 Adjusting headlamps

The beam from a headlamp is normally directed towards the ground ahead of the vehicle for a low beam (approximately 40 m), and straight ahead for a high beam (approximately 100 m).

In order to better determine beam orientation, a perpendicular screen is placed in front of the vehicle at a somewhat shorter distance (a minimum of 10 m). On this screen, at the same height, and relative to the vehicle axis, the position of the headlamps are indicated.

The lamps can thus be adjusted and checked, taking in account the required inclination settings.

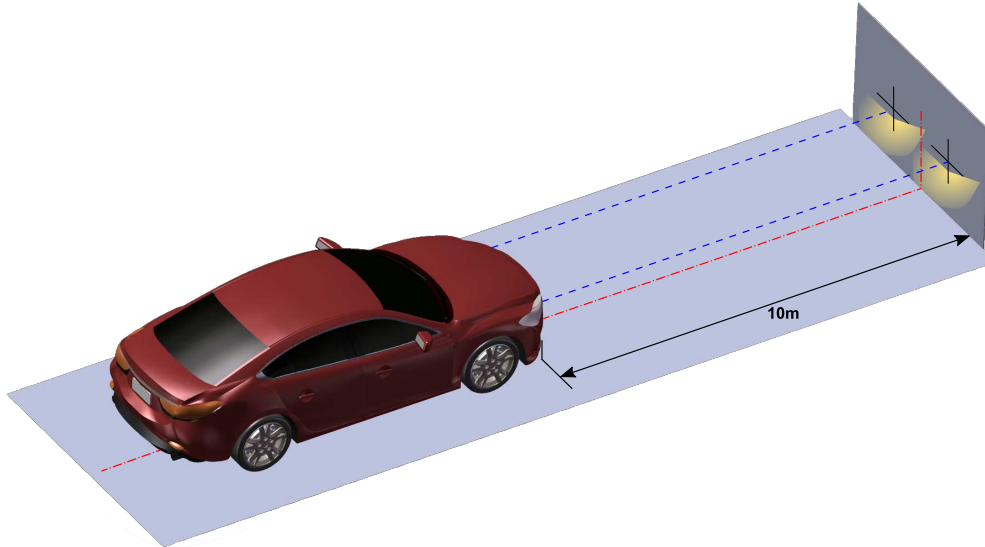

Figure 2: Basic principle of headlamp aiming on a 10m wall

If a white screen is placed at a distance of 10 m in front of the headlamp, the inclination angle (slope) of the headlamp under test can be determined and expressed in *cm/10m* or *%*. This kind of projection screen is also called a *10m wall*.

**L** is the distance between the headlamp and the projection screen and is equal to 10 m. The horizontal blue dotted line in the image below indicates the *mounting height* of the headlamp. This height should be marked on the *10m wall*. The sloped dotted line represents the beam projection of the *cut-off line* of the low beam. The inclination angle (slope) of the headlamp is indicated as  $\alpha$  and can be expressed in degrees.

**H** represents the distance between the *mounting height* of the headlamp and the beam projection of the *cutoff line*, measured on the *10m wall*. If  $L=10$  m and  $H=10$  cm, the headlamp inclination is equal to 10 cm/10m, or 1%.

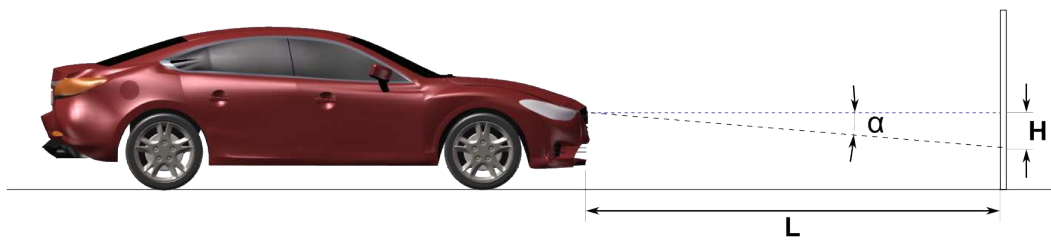

Figure 3: Beam slope

The following table provides the eventually needed conversion between the different units.

cm/10m	15	14	13	12	11	10	9	8	7	6	5	4	3	2	1	0
%	1.5	1.4	1.3	1.2	1.1	1	0.9	0.8	0.7	0.6	0.5	0.4	0.3	0.2	0.1	0
inch/25feet	4.5	4	3.5	3	2.5	2	1.5	1	0.5	0						
degrees	0.8			0.6			0.4			0.2						0

Figure 4: Unit conversion

This method has some disadvantages:

- It requires an indoor open area, over 10 meters long.
- The illumination level of that area has to be constant, mainly dimmed and not subject to the varying conditions of natural light.
- The axes must be meticulously specified for each and every different vehicle and for any new vehicle alignment process.
- The method is purely visual and highly dependent on the operator skills and interpretation.

## 2.3 Lens Principle

The use of a converging lens placed at the focal length reduces the distance to the screen dramatically and eliminates the need of a dark room.

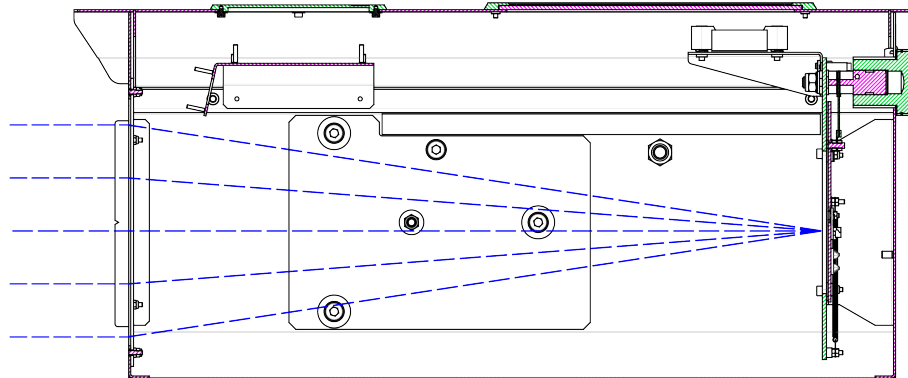

Figure 5: Parallel light rays entering the lens

All parallel rays from the same direction are concentrated in one point on the white projection screen inside the Luminoscope®.

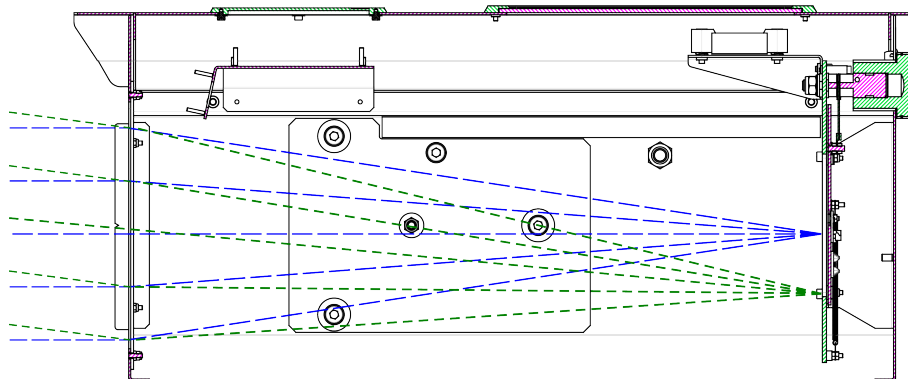

Figure 6: Parallel light rays from different angles entering the lens

Every point on the screen represents a collection of rays from the same direction.

## 2.4 Advantages of optical block with lens

The use of a collecting lens has advantages over the *10m wall* projection method.

- The distance to the screen is dramatically reduced: from 10 m to 0,5 m.
- The beam intensity is much higher, dimming or cancelling the ambient light is no longer necessary.
- The white projection screen is positioned at the focal distance of the lens. All parallel rays from the same direction are concentrated in one point. Consequently, the relative position of the system in relationship to the lamp becomes less important as the beam projection of the screen remains identical, independent of the place where the rays enter the lens.

## 2.5 Image projection

The beam pattern is projected at the white projection screen inside the Luminoscope® and can be visually assessed by means of the markings on the screen.

Depending on the target market and local regulations, the projection screen may present different aspect and features. Refer to the proper subchapter below describing the image projection screen of your SLA 7.

### 2.5.1 Standard image projection screen

The standard projection screen has the following layout:

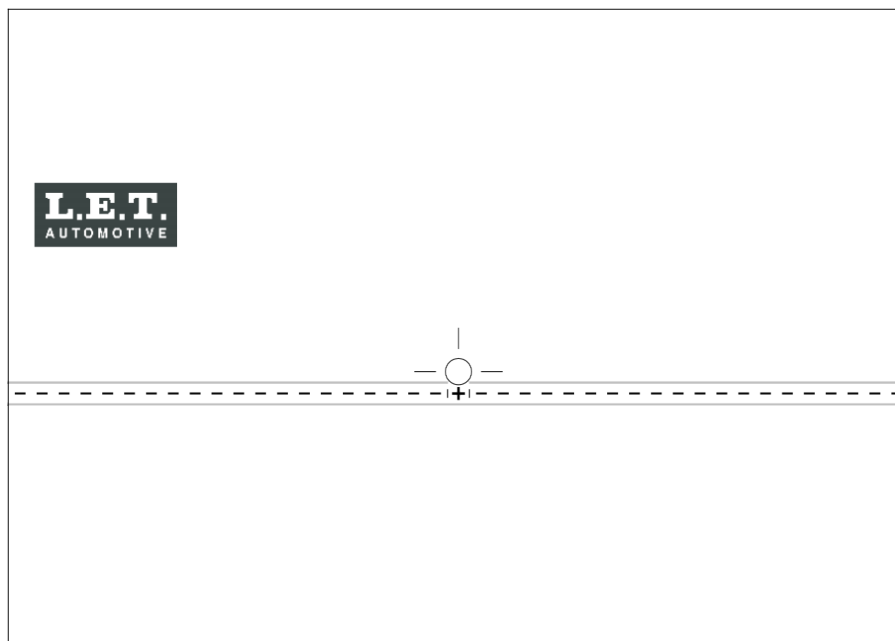

Figure 7: Projection screen with markings

Refer to the links below for a further explanation of the screens' markings and use.

#### Related information

[Standard movable screen](#) (pg. 55)

### 2.5.2 UK image projection screen

SLA 7 units for the UK comply with local regulations and provide specific markings and patterns, as dictated by the DVSA and, depending on their intended use, they are provided with one of the two following alternative projection screens.

Luminoscope® units used to test vehicles other than HGVs, have a standard screen like the one shown below.

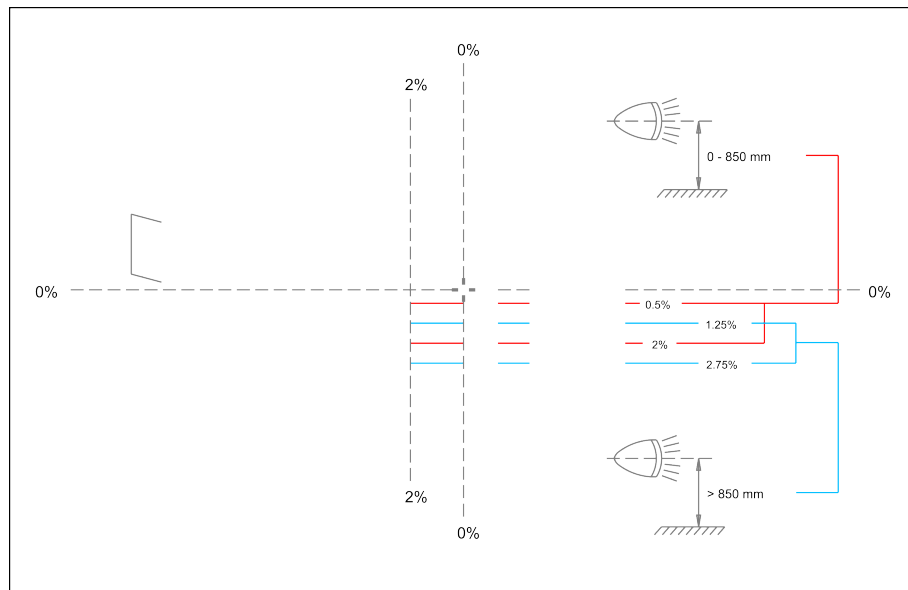

Figure 8: Projection screen for UK for MOT vehicles

For testing HGVs, the Luminoscope® has a special screen.

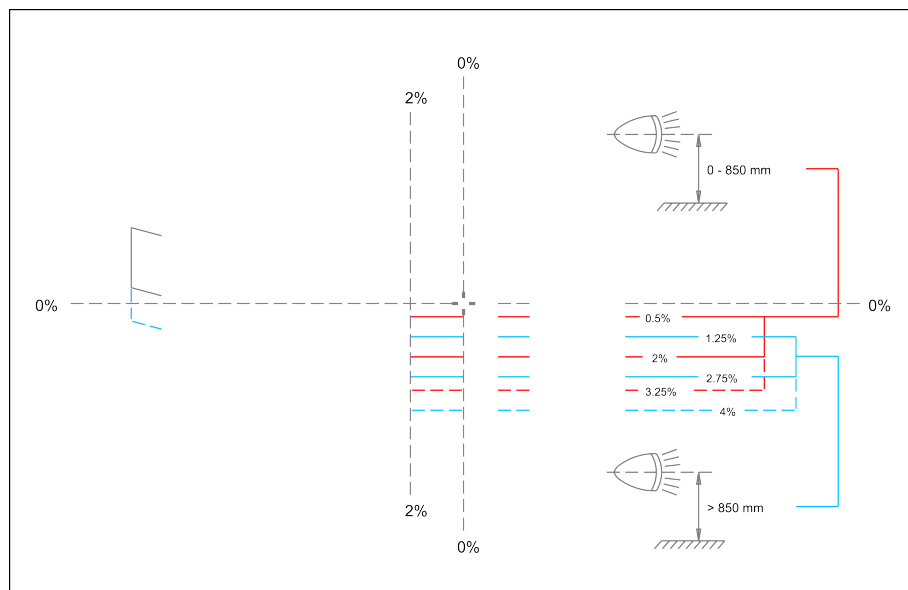

Figure 9: Projection screen for UK for HGV vehicles

Refer to the link below for further clarification on the use of these screens.

#### Related information

[Fixed DVSA screen \(pg. 55\)](#)

## 2.6 Alignment with the vehicle

In order to obtain a reliable measurement of the headlamp, it is necessary to achieve a good alignment of the Luminoscope® with the slope of the vehicle standing area and the longitudinal axis of the vehicle.

### In the horizontal plane

---

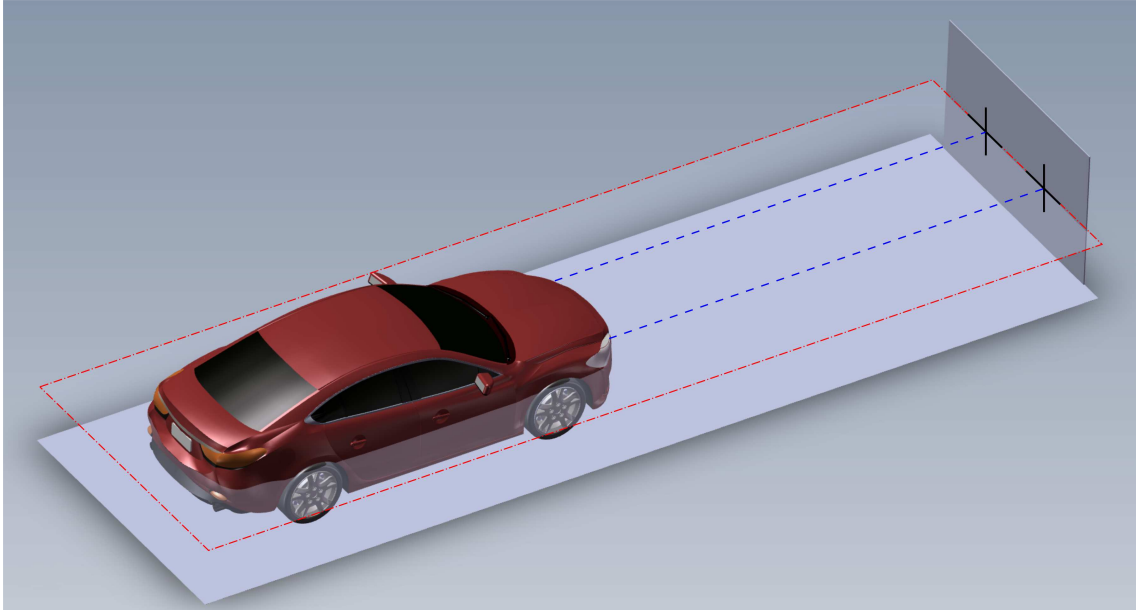

Figure 10: Horizontal plane alignment

The easiest way to achieve a good horizontal alignment with the vehicle is to place the vehicle on a horizontal floor and set the optical block also horizontal with the aid of the spirit level. In practice not so many floors are perfectly horizontal. There are two practical methods to achieve it:

- Measure the floor slope (check corresponding manual) and tilt the optical block in the same direction with the same slope.
- Measure the floor slope and add or subtract that value (depending on the direction of the floor slope) to the computed value of the beam position by the optical block.

### In the vertical plane

---

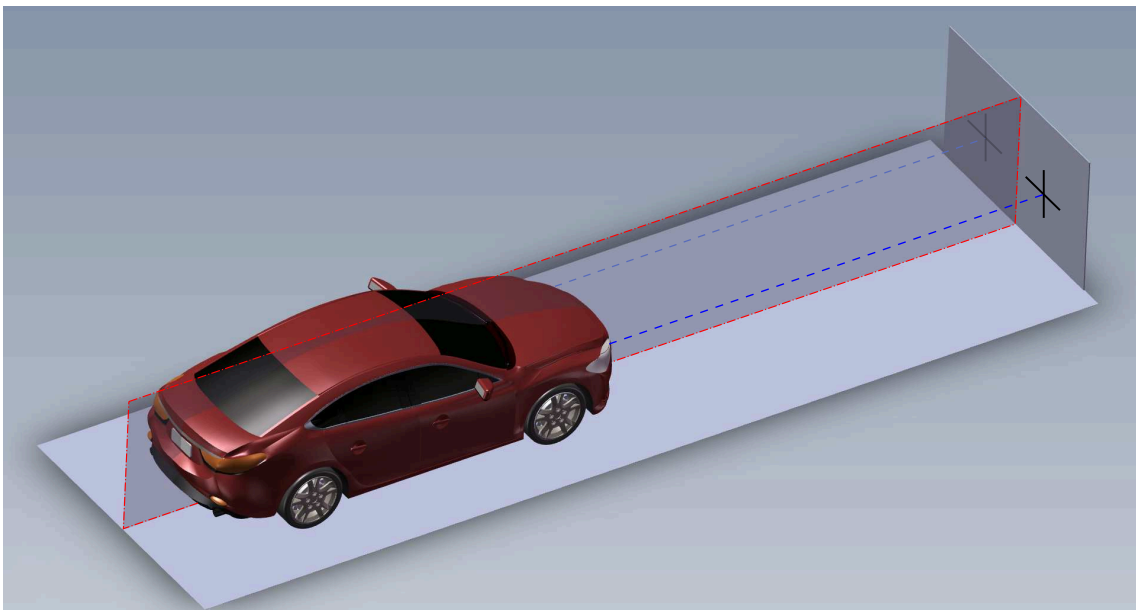

Figure 11: Vertical plane alignment

The precision of the measurement of the L/R position of the beam depends mainly on the vertical alignment of the vehicle towards the optical block. As an example, a simple misalignment

of 5 mm on a wheelbase of 2 m will give an error of  $5 \times 5 \text{ mm} = 2.5 \text{ cm}/10\text{m}$  in the L/R measurement of the beam.

The vertical plane is also called the *longitudinal direction* of the vehicle.

This procedure ensures the longitudinal alignment between the Luminoscope® and the vehicle longitudinal axis.

## 2.7 Positioning in front of the headlamp

It is of great importance that the lens of the Luminoscope® is correctly positioned in front of the headlamp to ensure that as many light rays as possible enter the lens.

This guarantees that the beam image is displayed realistically on the white projection screen inside the Luminoscope® to be able to perform a correct headlamp measurement.

With this purpose, the front of the Luminoscope® has three markings 1 and 2 indicating the centre of the lens. This can help the operator to correctly position the lens of the Luminoscope® in front of the headlamp.

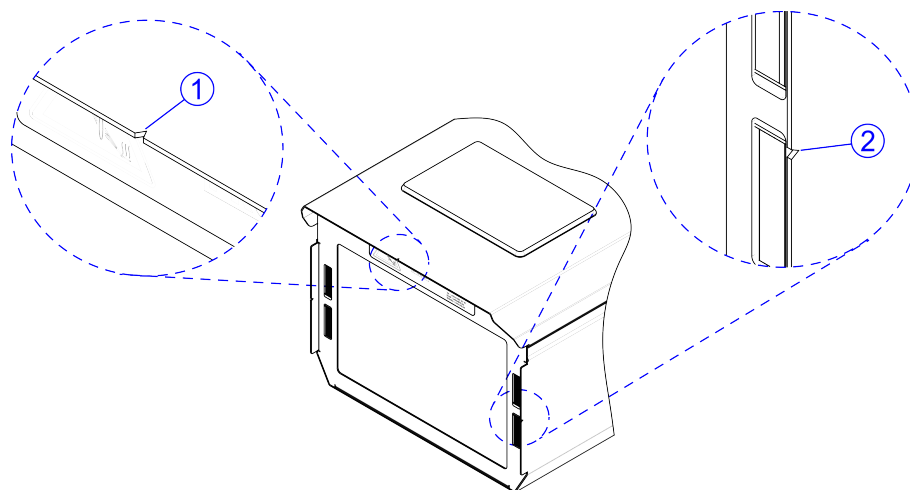

Figure 12: Central markings on the lens front



---

# 3 Headlamps

---

This is a review of the illumination patterns that different headlamps produce.

## 3.1 ECE or European low beam



**Note:** Both terms *low beam* and *dipped beam* refer to the same type of headlamp and are used interchangeably.

The purpose of the low beam is to illuminate the road ahead of the vehicle and traffic signs up to a distance of approximately 40 m without blinding oncoming traffic. The asymmetrical low beam must be adjusted on a predefined inclination value. In Europe e.g. it's an inclination between -1% (or -10 cm/10m) and -1.5% (or -15 cm/10m). The reference point of the beam is the intersection of the horizontal part with the sloped part and is referred to as *V-point*. It is also called *kink point* and *elbow point*.

There exist two types of ECE low beams, depending on which side of the road the vehicle is driving:

### LHD (Left Hand Drive)

---

The steering wheel is positioned on the left side of the vehicle and the driver uses the right side of the road. Some examples of countries on which this driving type is implemented include (but are not limited to) Belgium, France and Germany, among many others.

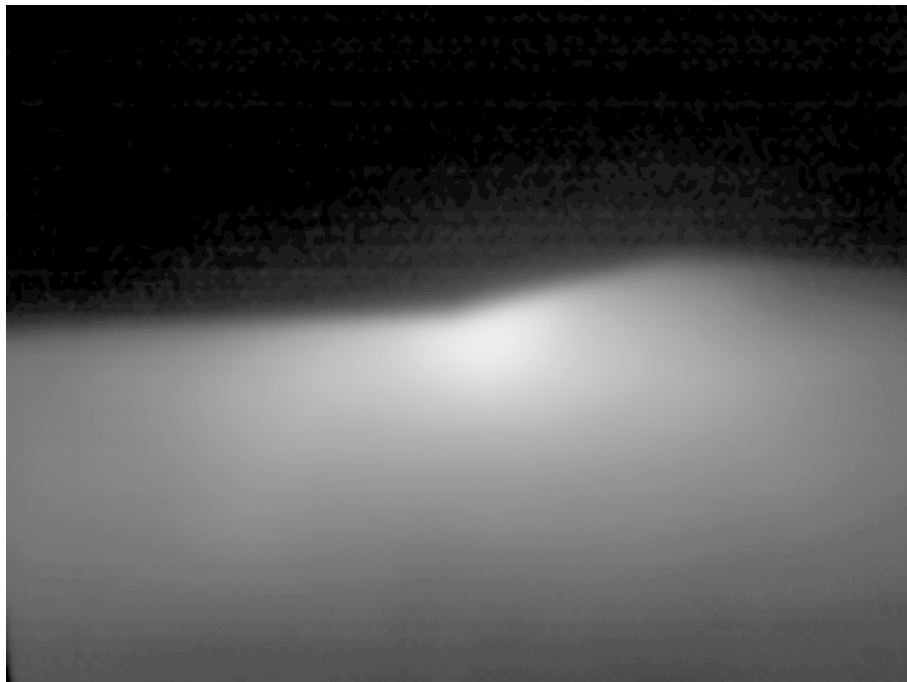

Figure 13: Low beam LHD

### RHD (Right Hand Drive)

---

The steering wheel is positioned on the right side of the vehicle and the driver uses the left side of the road. Some examples of countries on which this driving type is implemented include Great

Britain, Ireland, Japan, Thailand, Malaysia, Indonesia, New Zealand, Australia, India, South Africa, among many others.

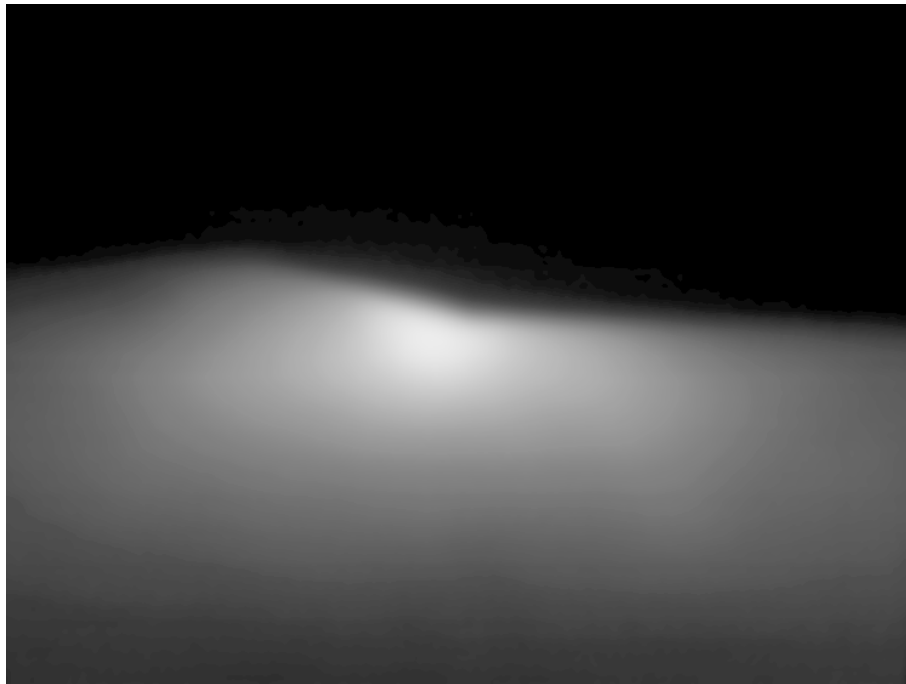

Figure 14: Low beam RHD

The world map below shows the implemented driving types for each country.

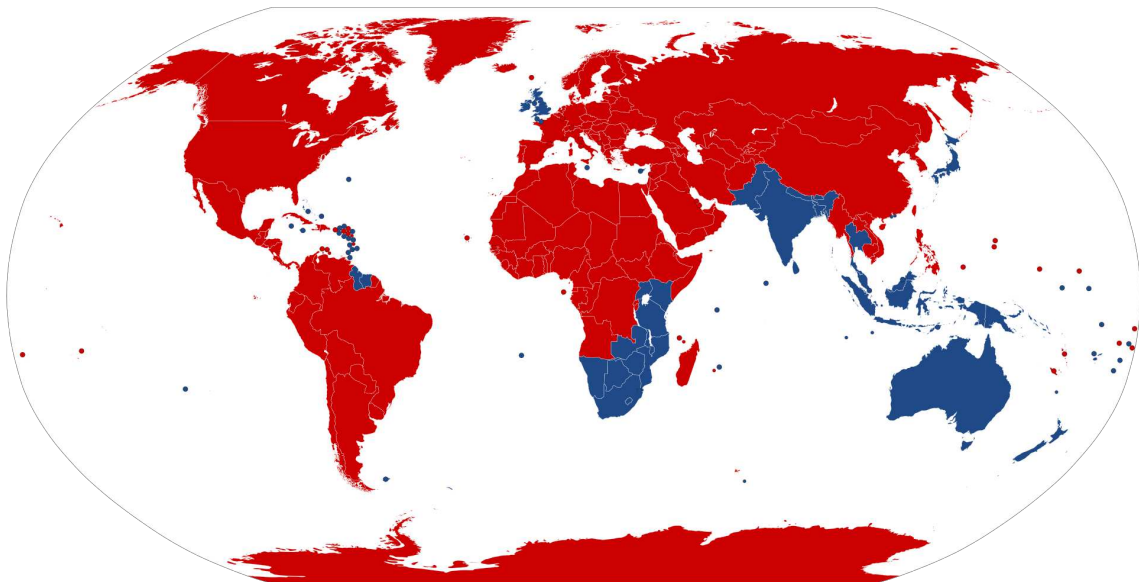

Figure 15: Implementation of LHD and RHD driving types across the world

## 3.2 High beam



**Note:** The terms *high beam* and *main beam* refer to the same type of headlamp and are used interchangeably.

The purpose of the high beam is to illuminate the road ahead of the vehicle at a further distance of approximately 100 m. The form of the beam is rather oval. The reference point is the point with the highest intensity (hotspot).

There are two different ways of construction:

- The high beam is integrated in the same housing of the low beam. Consequently, it is not possible to separately adjust high and low beams. In most countries, only the low beam is adjusted because this is the driving beam. Due to the construction of the headlamp, the high beam will be at fixed inclination value that is 1% or 10 cm/10m higher than the low beam value.
- The high beam is a standalone headlamp and both beams can be separately adjusted with their own adjusting screws. Adjustment of the high beam is done at a value of 1% or 10 cm/10m higher than the low beam value.

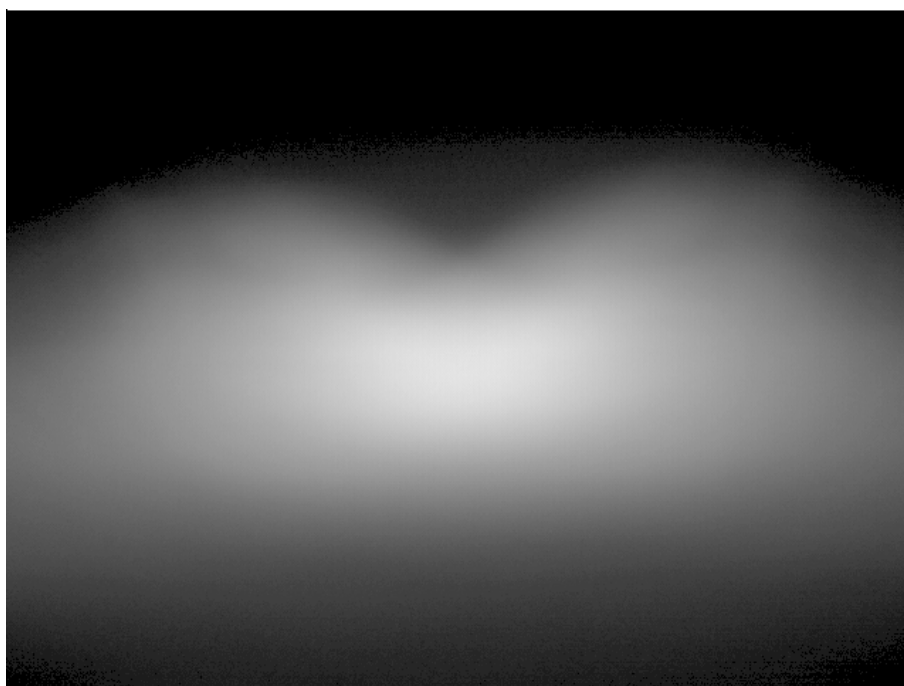

Figure 16: High beam

### 3.3 Fog beam

Fog beams are mounted at the front bottom of the vehicle and illuminate the road as far as possible under fog, heavy rain or snow conditions.

The form of the beam is a broad band of light, where the reference is the flat horizontal top line (*cut-off line*) which is normally adjusted at 1% or 10 cm/10m below the low beam value. A fog beam only has one adjusting screw controlling the inclination.

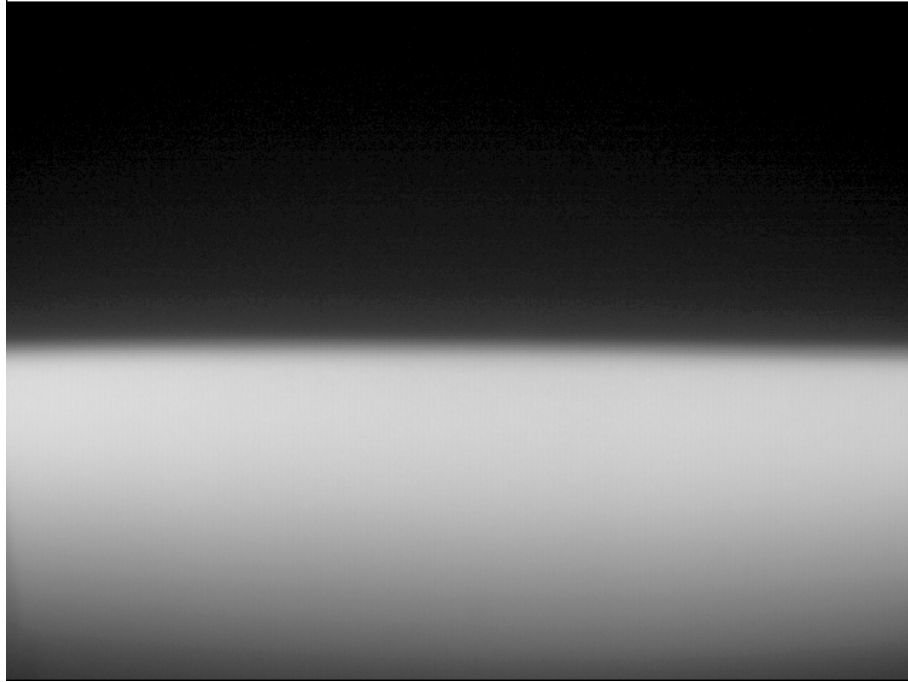

Figure 17: Fog beam

### 3.4 SAE or American low beam



**Note:** Both terms *low beam* and *dipped beam* refer to the same type of headlamp and are used interchangeably.

SAE (Society of Automotive Engineers)/ American low beams have an LHD shaped *cut-off line* with a small step and a zone of high intensity (*hotspot*) on the right side of the small step.

American low beams must be aimed – according to the marking on the glass – referring to the left or right side of the *cut-off line*.

There are two types of American low beams, requiring different adjustment methods:

**VOL - Visually Optical Left**

The left part of the *cut-off line* should be aimed at an inclination of -0,7%.

**VOR - Visually Optical Right**

The right part of the *cut-off line* should be aimed at an inclination of 0%.

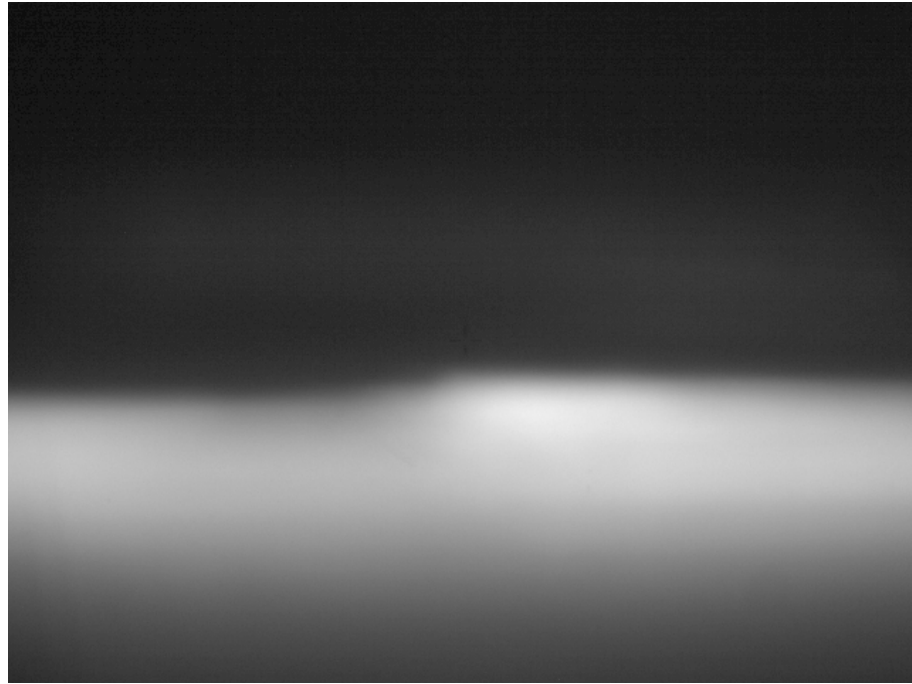

Figure 18: SAE low beam VOL or VOR

### 3.5 Japanese low beam



**Note:** Both terms *low beam* and *dipped beam* refer to the same type of headlamp and are used interchangeably.

The Japanese low beam has some similarities with a mirrored image of the SAE low beam, because the Japanese driver uses the left side of the road (RHD). However, there are subtle details regarding the different heights of the zones at both sides of the step which make them different.

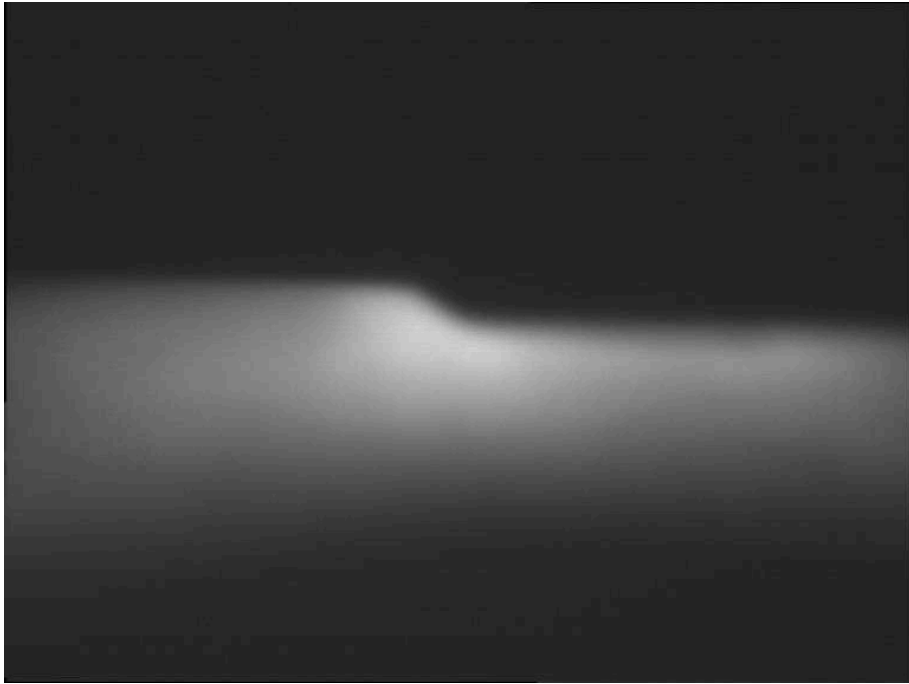

*Figure 19: Japanese low beam*

---

# 4 Prerequisites for checking or adjusting

---

In order to achieve an accurate and stable headlamp measurement or adjustment, a number of prerequisites must be taken care of.

## 4.1 Prerequisites for the vehicle

- The front wheels must be in the straight-line travel position.
- The tires should be inflated to manufacturer specified pressures.
- The vehicle should be empty, with the handbrake released.
- The springs and the shock-absorbers should be in their equilibrium positions. For vehicles with hydro-pneumatic suspension, the motor should be running.
- When the vehicle is equipped with a manual control to adjust the low beam, verify that it is in its rest position.

## 4.2 Prerequisites for the headlamps

- Check that the headlamps are rigidly connected to the vehicle.
- Check whether the two lamp glasses are identical, whether they are in their correct angular position and that they are not cracked.
- Check that the lamp glasses are clean and whether the reflectors are in a satisfactory state.
- Check that the headlamp units neither contain any water, nor are misted up.

## 4.3 Positioning the system

- Locate the vehicle approximately 20-60 cm from the lens of the headlamp tester.



# 5 Technical characteristics

## 5.1 SLA 7 models

Depending on the provided guiding system, there are different Luminoscope® models available.

Types	Standard column + standard trolley	Long column + standard trolley	Standard column + wide trolley	Long column + wide trolley	Description
Double rail	DR	DR L	DR D	DR D L	The two V-shaped front wheels of the trolley base are guided on a hexagonal rail. The simple flat wheel runs on the square rail. The uniform levelling of the rails can be easily adjusted to obtain a perfect horizontal movement over the whole length of the rails.
Single rail	SR	SR L	SR D	SR D L	The two rubber front wheels of the trolley are guided on a simple V-shaped steel rail, attached to the floor. The rubber rear wheel runs on the floor. There is no adjustment mechanism provided to adjust the uniform levelling of the rail.
No rail	NR	NR L	NR D	NR D L	The three rubber wheels of the trolley base run on the floor. The Luminoscope® can be used on different locations which have identical floor slope for the vehicle standing area.



**Note:**

- **L** models are provided with a longer column, extending their vertical range in 200 mm. This extra length makes the unit suitable for vehicles with higher headlamps mounting, such as some trucks, buses and other special purpose vehicles.
- **D** trolley units are provided with a versatile base with a different shape than the standard trolley base. The **D** trolley base can be equipped with different wheel types and different tracking distances.

**Luminoscope® SLA 7 DR**

---

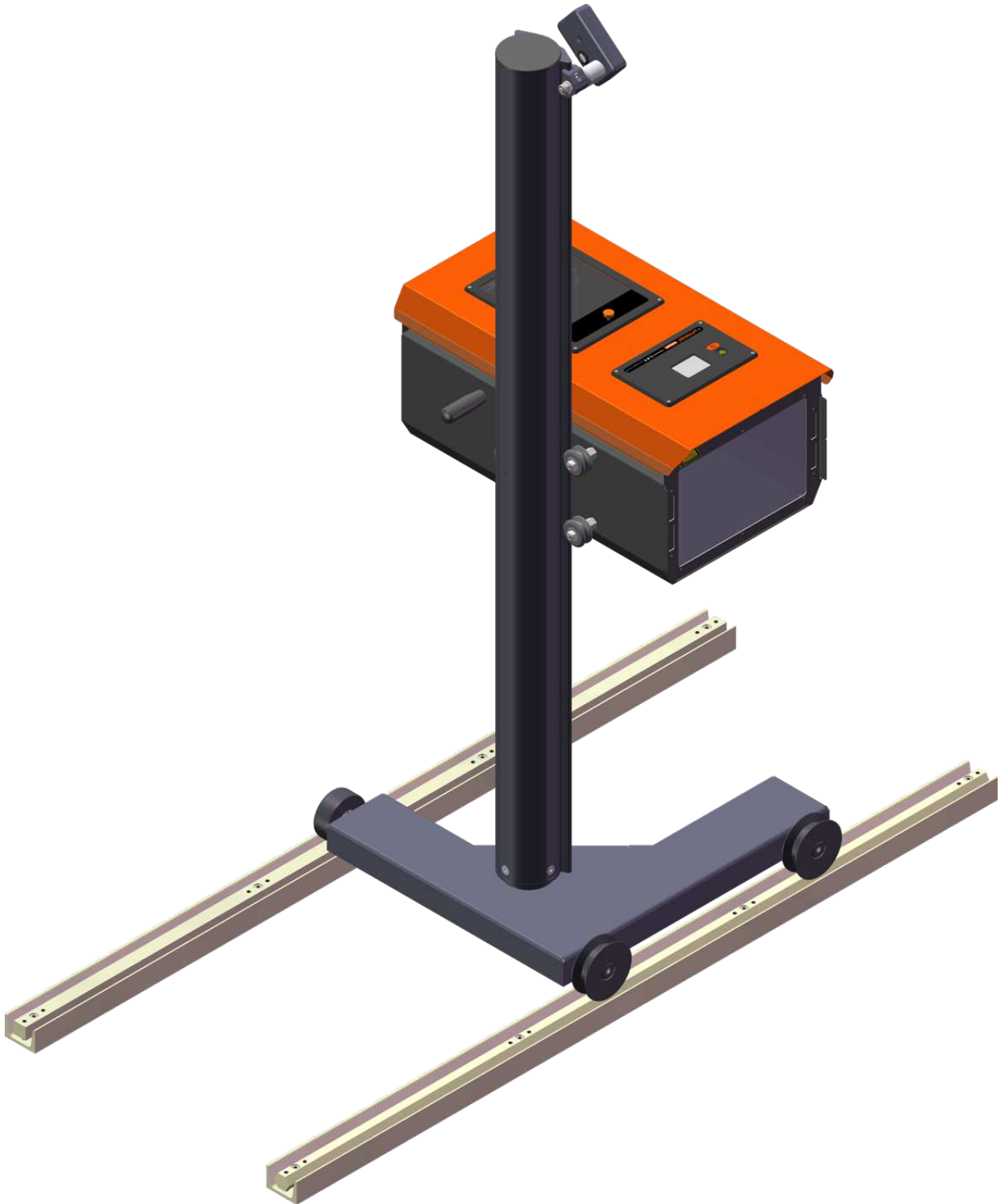

*Figure 20: General view of Double Rail model (SLA 7 DR)*

**Luminoscope® SLA 7 SR**

*Figure 21: General view of Single Rail model (SLA 7 SR)*

**Luminoscope® SLA 7 NR**

*Figure 22: General view of No Rail model (SLA 7 NR)*

## 5.2 Guiding systems

The two front wheels of the trolley base of the Luminoscope® SLA 7 can be guided on one non-adjustable rail profile that is fixed to the floor. Other systems are guided on two robust adjustable rails which are fixed to the floor or recessed in the floor.

Guiding the Luminoscope® SLA 7 on rails ensures an easier alignment of the Luminoscope® with the vehicle. In case the rails are adjustable, the Luminoscope® remains horizontally along the entire range of the rails.

Luminoscope® SLA 7 systems without guiding rails are also available. In this case, the rubber wheels of the trolley base are just running on the floor. The equipment can be used on different locations which have the same floor slope for the vehicle standing area.

On systems with non-adjustable rails or without any rails, the inclination of the optical block will subtly vary without any doubt while displacing the system. This has a direct consequence on the measurement results of the Luminoscope®.

There are three different guiding systems available, depending on the use or type of rail:

- DR – Double Rail
- SR – Single Rail
- NR – No Rail

### 5.2.1 SLA 7 DR: double rail

The two V-shaped front wheels 1 of the trolley base are guided on a hexagonal rail 2. The simple flat rear wheel 3 runs on the square rail 4. The uniform levelling of the rails can be easily adjusted to obtain a perfect horizontal movement of the Luminoscope® over the entire length of the rails.

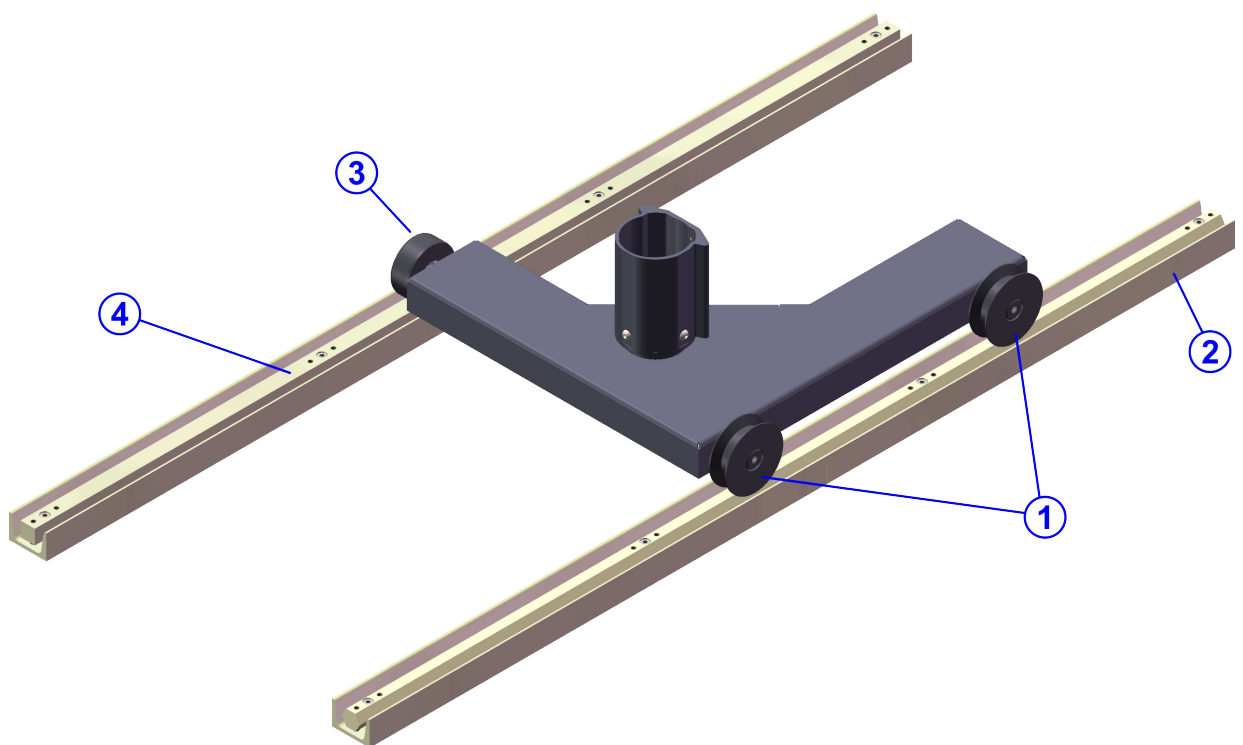

Figure 23: Double rail (DR)

### 5.2.2 SLA 7 SR: single rail

The two front rubber wheels 1 of the trolley base are guided on a simple V-shaped steel rail 2, attached to the floor. The rear rubber wheel 3 runs on the floor.

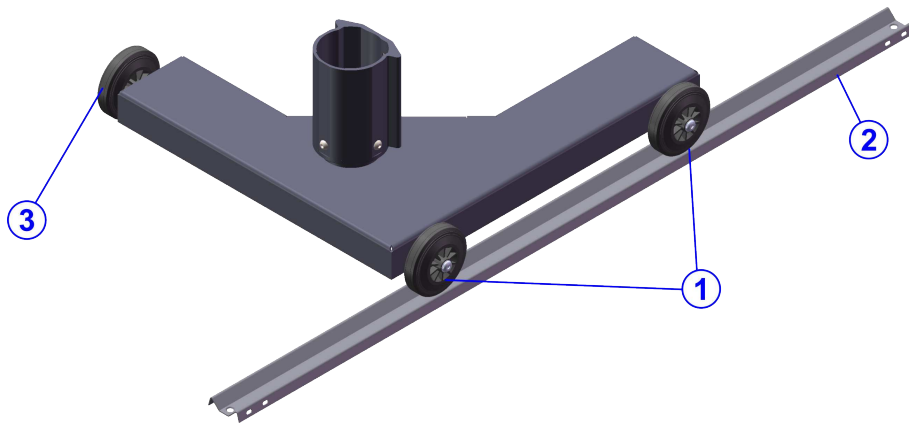

Figure 24: Single rail (SR)

There is no adjusting mechanism provided to adjust the uniform levelling of the rail.

### 5.2.3 SLA 7 NR: no rail

The three rubber wheels of the trolley base run on the floor.

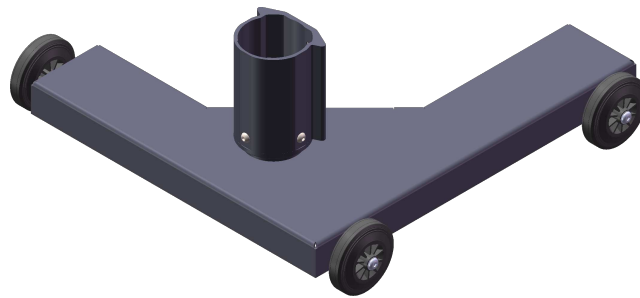

Figure 25: No rail (NR)

The system can be used on different locations which have an identical floor slope for the vehicle standing area.

## 5.3 Layout

The following sections include detailed graphics and callouts of the Luminoscope® which lead to an easier identification of the different parts and models.



**Note:** Depending on the ordered options or local regulations, the supplied unit may look slightly different from the following drawings.

## 5.3.1 Front view

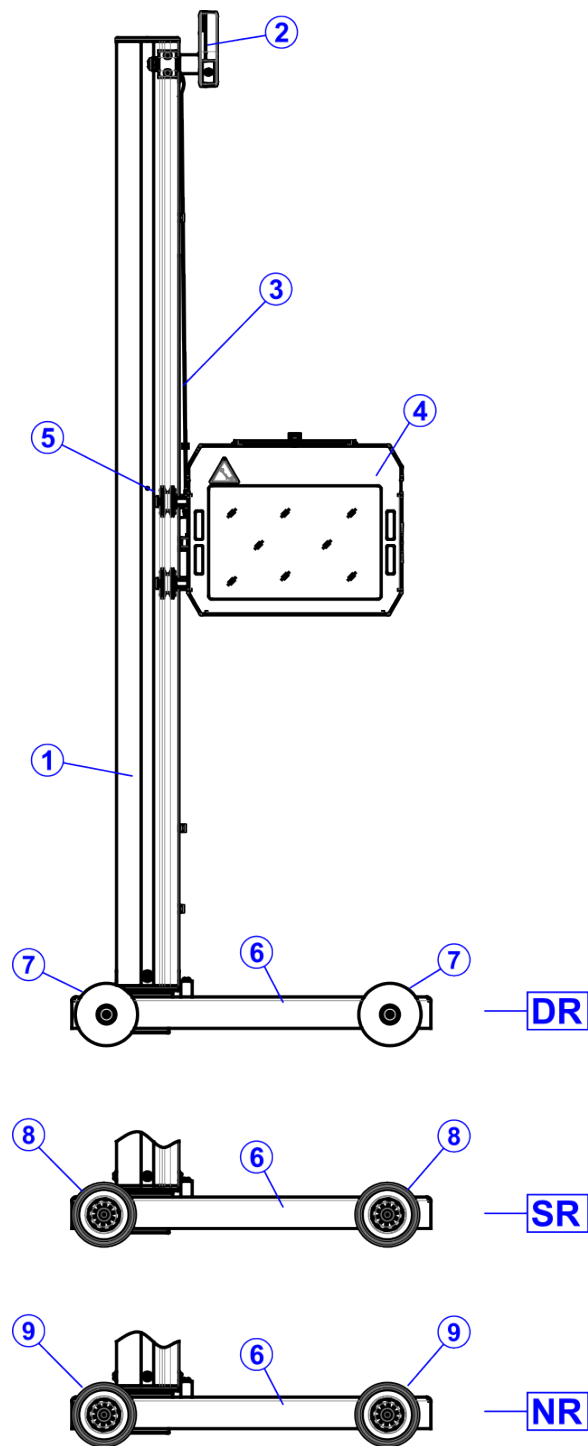

Figure 26: Front view of the Luminoscope®

#	Part	Description
1	Stand	The optical block is attached to the vertical fins of the stand.
2	Green alignment laser	Used to align the optical axis of the optical block with the longitudinal axis of the vehicle.
3	Counterweight cable	Connects the optical block with the counterweight inside the stand.

#	Part	Description
4	Optical block	The optical block includes a lens, a white projection screen, a digital camera, a control panel and a connector plate. Captures, processes and analyzes the headlight beam projection.
5	Vertical V-wheels	V-wheels sliding vertically on the fins of the column.
6	Trolley base	The trolley base on wheels ensures the stability and the perpendicularity of the system.
7	V-wheel with eccentric axle	Front wheel guides the system on the hexagonal rail. Provided with an eccentrical axis which allows the vertical adjustment of the stand.
8	Rubber wheel with eccentric axle	The rubber wheel runs on a non-adjustable rail profile. Provided with an eccentrical axis which allows the vertical adjustment of the stand.
9	Rubber wheel with eccentric axle	The rubber wheel runs on the floor. Provided with an eccentrical axis which allows the vertical adjustment of the stand.

### 5.3.2 Top view

#### SLA 7 DR

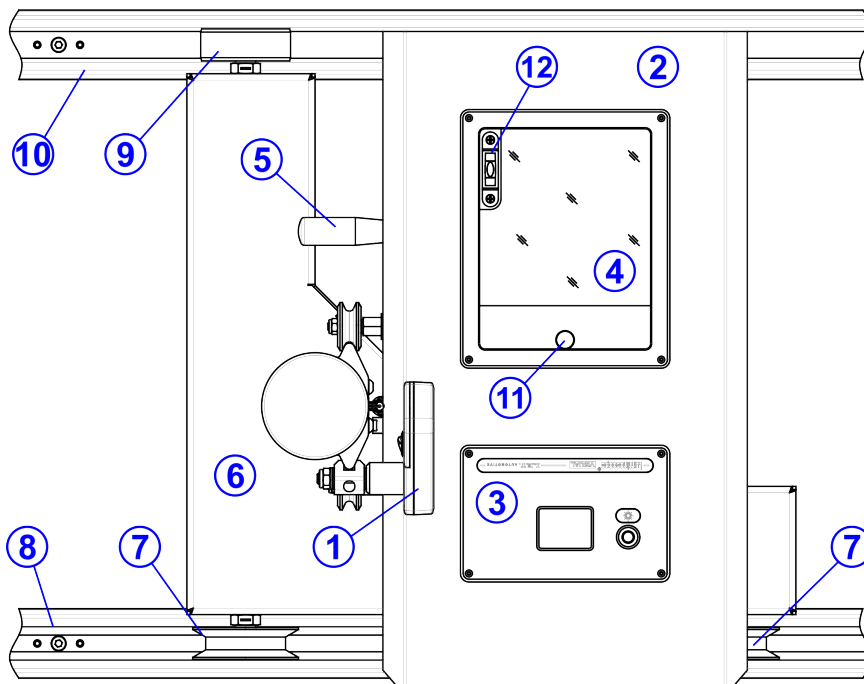

Figure 27: Top view Luminoscope® SLA 7 DR

#	Part	Description
1	Green alignment laser	Used to align the optical axis of the optical block with the longitudinal axis of the vehicle.
2	Optical block	The optical block includes a lens, a white projection screen, a digital camera, a control panel and a connector plate. Captures, processes and analyzes the headlight beam projection.

#	Part	Description
3	LIM (Light Intensity Module)	Optional module including a 2" LCD color screen displaying the intensity measurements of the headlight under test. Includes a button to trigger measurement and provides access to two 1.5V AA batteries by removing its four screws. An identification cover is supplied as alternative.
4	Perspex window	The headlight image on the projection screen inside the optical block is visible through this window.
5	Handle	Handle on the vertical sliding table to move the system and vertically displace the optical block.
6	Trolley base	The trolley base on wheels ensures the stability and the perpendicularity of the system.
7	V-wheel with eccentric axle	Front wheel guides the system on the hexagonal rail. Provided with an eccentric axis which allows the vertical adjustment of the stand.
8	Adjustable hexagonal rail profile	Adjustable hexagonal rail profile embedded in the floor, which guides the two front V-wheels of the trolley base.
9	Flat wheel with eccentric axle	Flat wheel running on the square rail. Provided with an eccentric axis which allows for the vertical adjustment of the stand.
10	Adjustable square rail profile	Adjustable square rail profile embedded in the floor, on which the rear flat wheel of the trolley base runs.
11	TLM (Tilting Looking Mirror) module	Optional adjustable mirror allowing an easier visual access to the headlamp projection in the internal white screen.
12	Reference spirit level	The reference spirit level is used as a tool to verify the calibration status of the optical block. The Luminoscope® is initially calibrated at the factory to a point on which the optical axis of the optical block is horizontal.

## SLA 7 SR

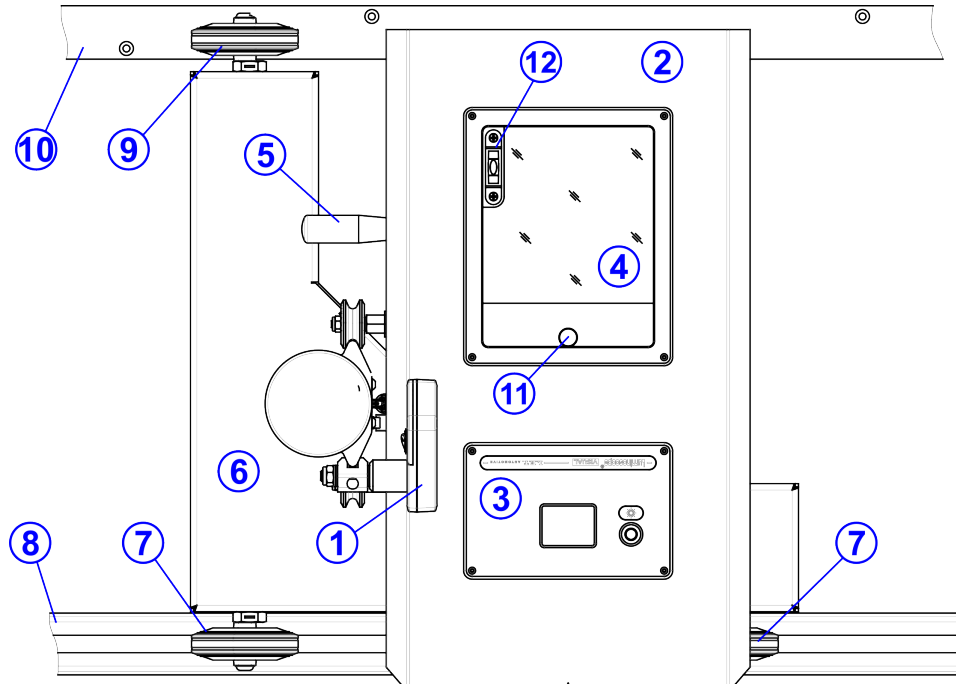

Figure 28: Top view Luminoscope® SLA 7 SR

#	Part	Description
1	Green alignment laser	Used to align the optical axis of the optical block with the longitudinal axis of the vehicle.
2	Optical block	The optical block includes a lens, a white projection screen, a digital camera, a control panel and a connector plate. Captures, processes and analyzes the headlight beam projection.
3	LIM (Light Intensity Module)	Optional module including a 2" LCD color screen displaying the intensity measurements of the headlight under test. Includes a button to trigger measurement and provides access to two 1.5V AA batteries by removing its four screws. An identification cover is supplied as alternative.
4	Perspex window	The headlight image on the projection screen inside the optical block is visible through this window.
5	Handle	Handle on the vertical sliding table to move the system and vertically displace the optical block.
6	Trolley base	The trolley base on wheels ensures the stability and the perpendicularity of the system.
7	Rubber wheel with eccentric axle	The rubber wheel runs on a non-adjustable rail profile. Provided with an eccentric axis which allows the vertical adjustment of the stand.
8	Non-adjustable rail profile	Non-adjustable rail profile mounted on the floor. The two front rubber wheels of the trolley base are guided on the rail.
9	Rubber wheel with eccentric axle	The rubber wheel runs on the floor. Provided with an eccentric axis which allows the vertical adjustment of the stand.

#	Part	Description
10	Special guiding rail	Special rail profile mounted on the floor, not supplied by LET. May be adjusted to ensure a flat continuous surface. Requires matching wheels which are available in the LET catalog.
11	TLM (Tilting Looking Mirror) module	Optional adjustable mirror allowing an easier visual access to the headlamp projection in the internal white screen.
12	Reference spirit level	The reference spirit level is used as a tool to verify the calibration status of the optical block. The Luminoscope® is initially calibrated at the factory to a point on which the optical axis of the optical block is horizontal.

## SLA 7 NR

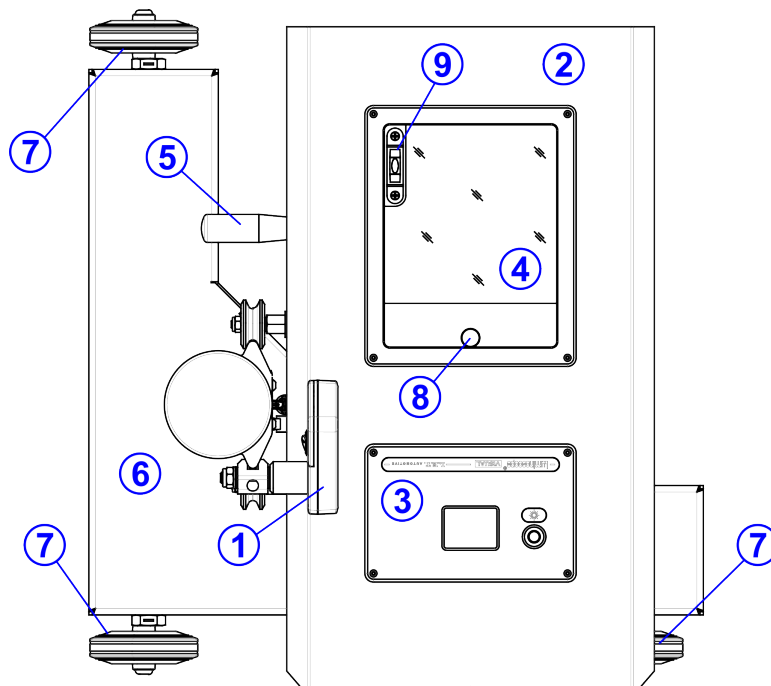

Figure 29: Top view Luminoscope® SLA 7 NR

#	Part	Description
1	Green alignment laser	Used to align the optical axis of the optical block with the longitudinal axis of the vehicle.
2	Optical block	The optical block includes a lens, a white projection screen, a digital camera, a control panel and a connector plate. Captures, processes and analyzes the headlight beam projection.
3	LIM (Light Intensity Module)	Optional module including a 2" LCD color screen displaying the intensity measurements of the headlight under test. Includes a button to trigger measurement and provides access to two 1.5V AA batteries by removing its four screws. An identification cover is supplied as alternative.

#	Part	Description
4	Perspex window	The headlight image on the projection screen inside the optical block is visible through this window.
5	Handle	Handle on the vertical sliding table to move the system and vertically displace the optical block.
6	Trolley base	The trolley base on wheels ensures the stability and the perpendicularity of the system.
7	Rubber wheel with eccentric axle	The rubber wheel runs on the floor. Provided with an eccentric axis which allows the vertical adjustment of the stand.
8	TLM (Tilting Looking Mirror) module	Optional adjustable mirror allowing an easier visual access to the headlamp projection in the internal white screen.
9	Reference spirit level	The reference spirit level is used as a tool to verify the calibration status of the optical block. The Luminoscope® is initially calibrated at the factory to a point on which the optical axis of the optical block is horizontal.

## 5.3.3 Left side view

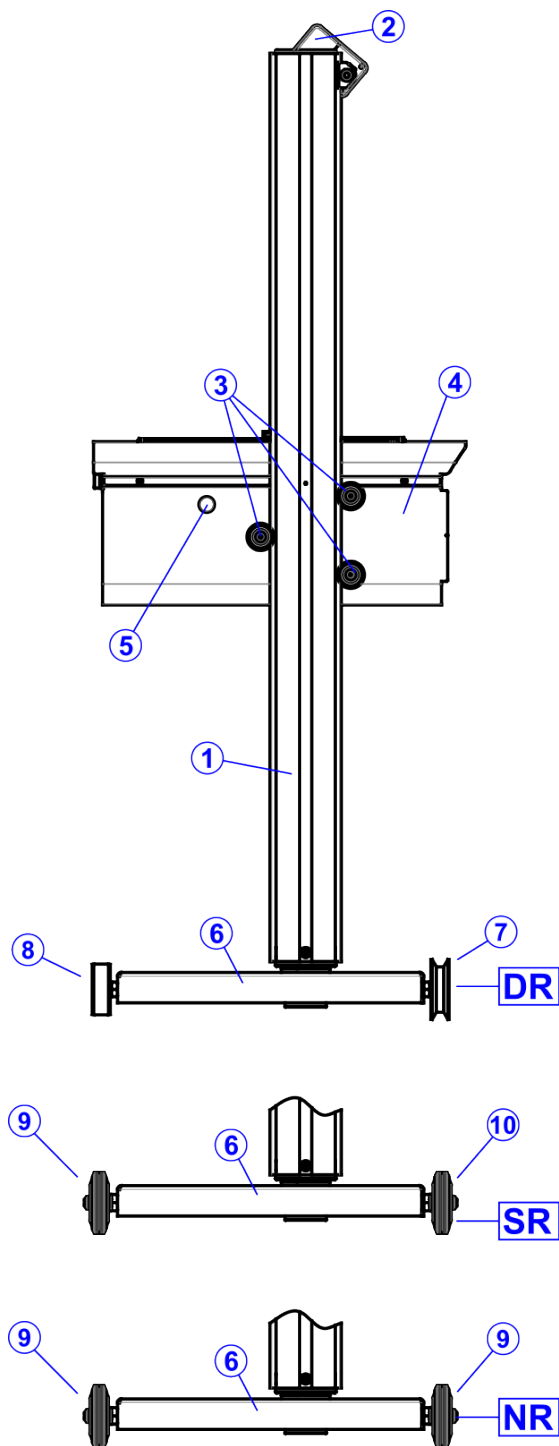

Figure 30: Left side view Luminoscope® SLA 7

#	Part	Description
1	Stand	The optical block is attached to the vertical fins of the stand.
2	Green alignment laser	Used to align the optical axis of the optical block with the longitudinal axis of the vehicle.
3	Vertical V-wheels	V-wheels sliding vertically on the fins of the column.

#	Part	Description
4	Optical block	The optical block includes a lens, a white projection screen, a digital camera, a control panel and a connector plate. Captures, processes and analyzes the headlight beam projection.
5	Handle	Handle on the vertical sliding table to move the system and vertically displace the optical block.
6	Trolley base	The trolley base on wheels ensures the stability and the perpendicularity of the system.
7	V-wheel with eccentric axle	Front wheel guides the system on the hexagonal rail. Provided with an eccentric axis which allows the vertical adjustment of the stand.
8	Flat wheel with eccentric axle	Flat wheel running on the square rail. Provided with an eccentric axis which allows for the vertical adjustment of the stand.
9	Rubber wheel with eccentric axle	The rubber wheel runs on the floor. Provided with an eccentric axis which allows the vertical adjustment of the stand.
10	Rubber wheel with eccentric axle	The rubber wheel runs on a non-adjustable rail profile. Provided with an eccentric axis which allows the vertical adjustment of the stand.

## 5.3.4 Right side view

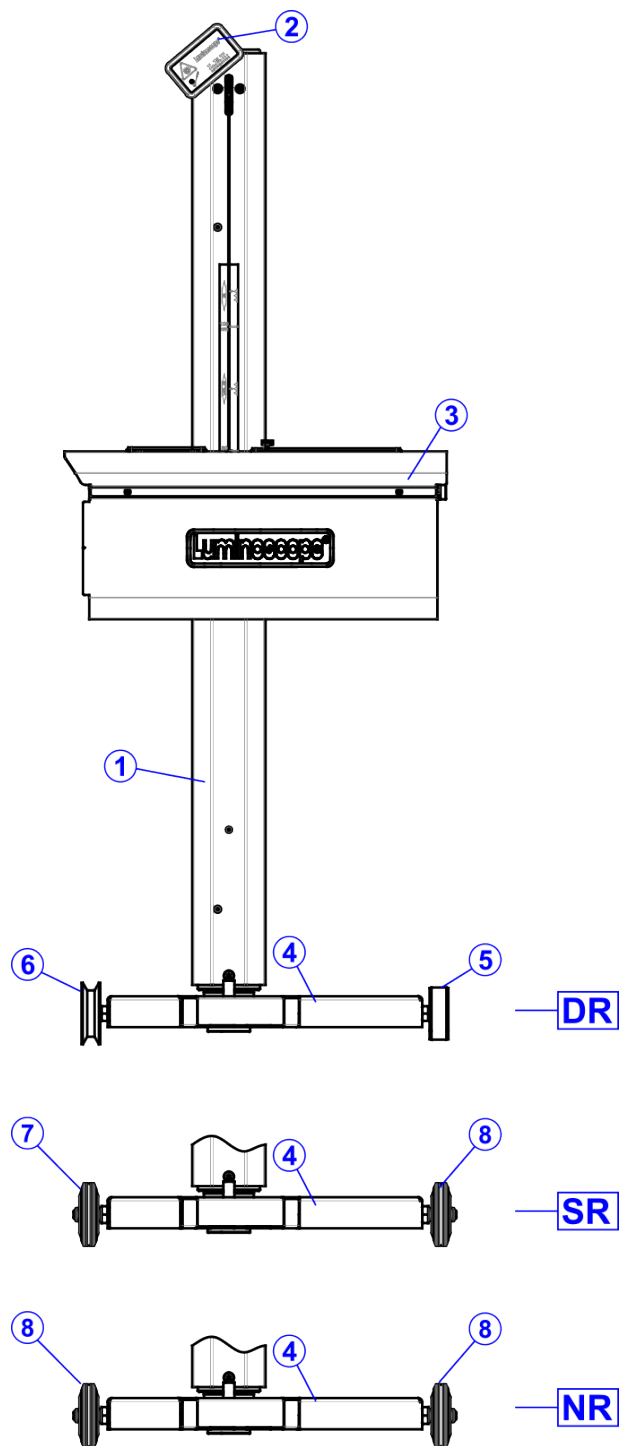

Figure 31: Right view Luminoscope® SLA 7

#	Part	Description
1	Stand	The optical block is attached to the vertical fins of the stand.
2	Green alignment laser	Used to align the optical axis of the optical block with the longitudinal axis of the vehicle.

#	Part	Description
3	Optical block	The optical block includes a lens, a white projection screen, a digital camera, a control panel and a connector plate. Captures, processes and analyzes the headlight beam projection.
4	Trolley base	The trolley base on wheels ensures the stability and the perpendicularity of the system.
5	Flat wheel with eccentric axle	Flat wheel running on the square rail. Provided with an eccentrical axis which allows for the vertical adjustment of the stand.
6	V-wheel with eccentric axle	Front wheel guides the system on the hexagonal rail. Provided with an eccentrical axis which allows the vertical adjustment of the stand.
7	Rubber wheel with eccentric axle	The rubber wheel runs on a non-adjustable rail profile. Provided with an eccentrical axis which allows the vertical adjustment of the stand.
8	Rubber wheel with eccentric axle	The rubber wheel runs on the floor. Provided with an eccentrical axis which allows the vertical adjustment of the stand.

### 5.3.5 Rear view

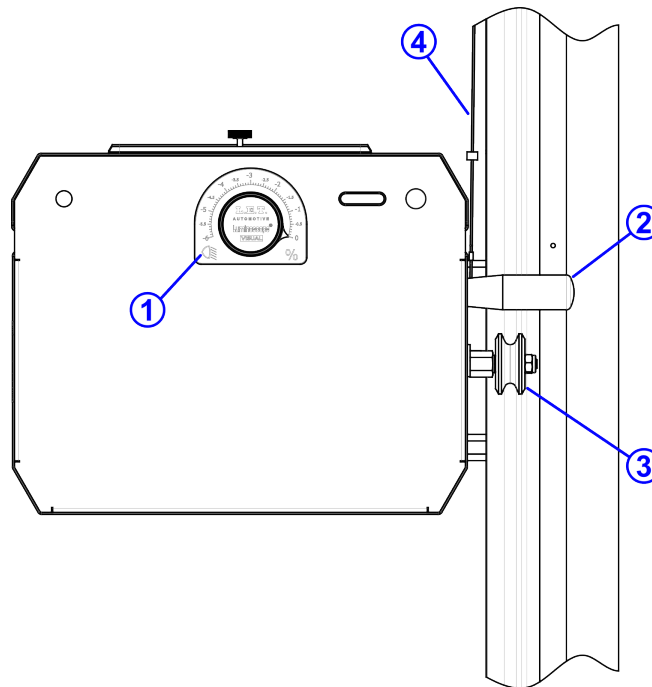



Figure 32: Rear view of the Luminoscope®

#	Part	Description
1	Rotary inclination knob	To adjust the vertical position of the internal projection screen. The chosen value on the knob corresponds with the vertical position of the low beam cut-off line at the projection screen.   <b>Note:</b> Only included in models with movable projection screen.
2	Vertical V-wheels	V-wheels sliding vertically on the fins of the column.
3	Handle	Handle on the vertical sliding table to move the system and vertically displace the optical block.
4	Counterweight cable	Connects the optical block with the counterweight inside the stand.

### 5.3.6 Alignment laser

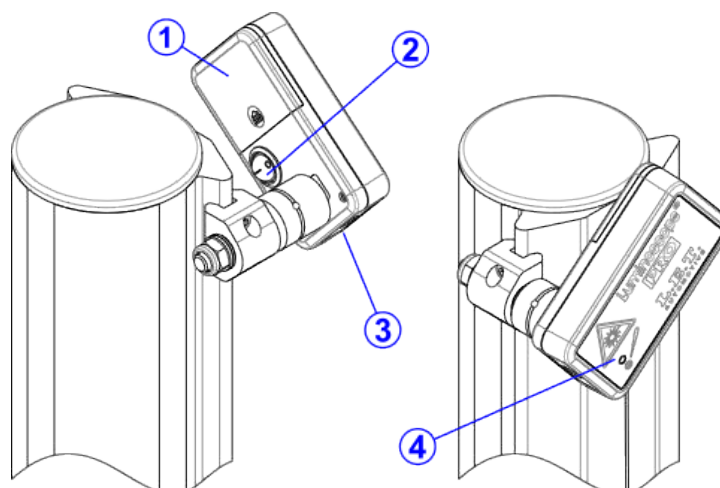
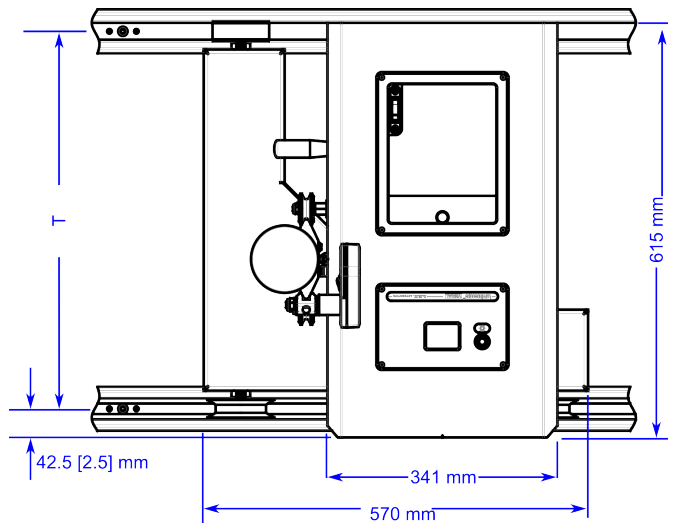
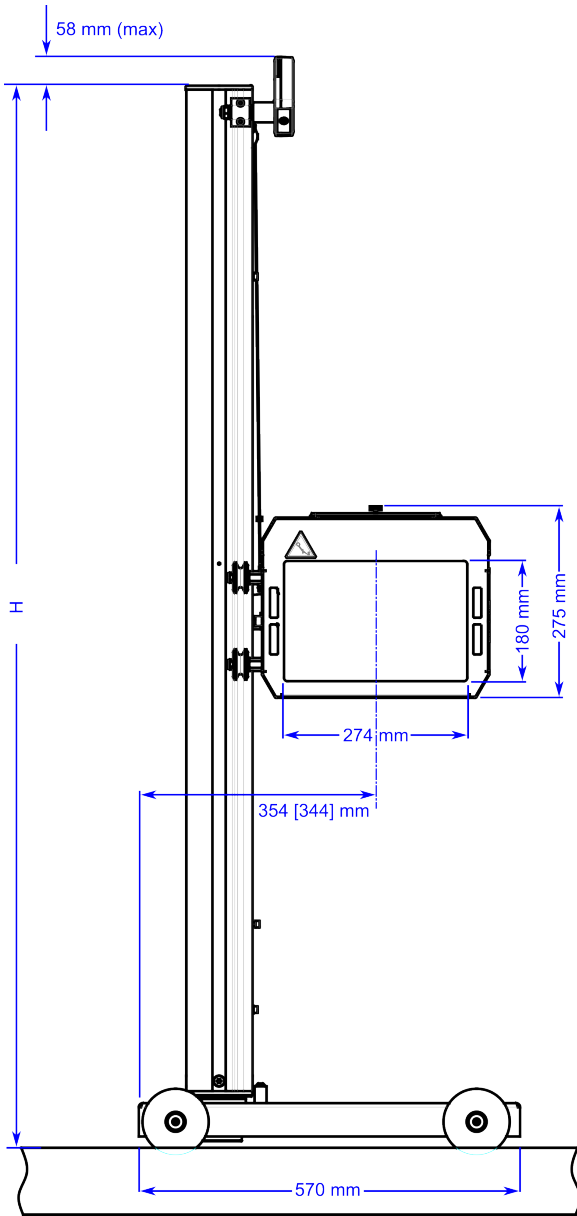

Figure 33: Alignment laser assembly

#	Part	Description
1	Battery lid	Remove it for substituting the laser batteries (2x AA alkaline cells, 1,5V).
2	Laser On-Off switch	Controls the power for the green alignment laser.
3	Green alignment laser	Used to align the optical axis of the optical block with the longitudinal axis of the vehicle.
4	Laser alignment screw	Access for an internal screw controlling the perpendicularity of the line laser beam.

## 5.4 Dimensions

### 5.4.1 SLA 7 DR



Height of the column (H) from ground level (in mm) considering standard DR rails, floor embedded

Standard	Long
1591	1791

Rail tracking distance between axis [T] (mm)

Model 394	Model 560	Model 585	Model 660
394	560	585	660



**Note:** Dimensions between brackets apply to wide-trolley models.

### 5.4.2 SLA 7 SR

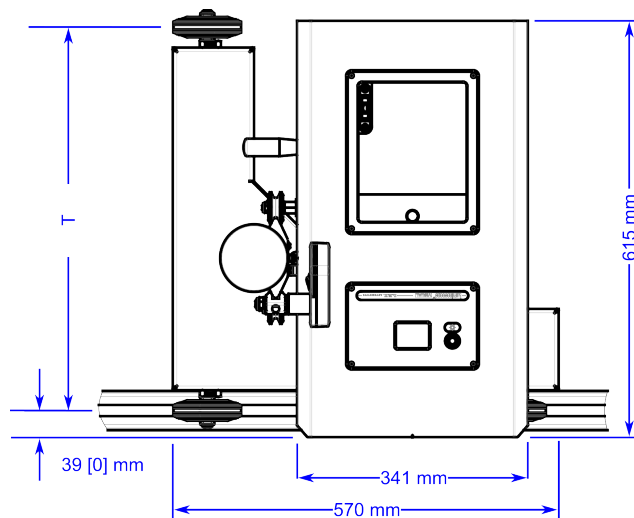
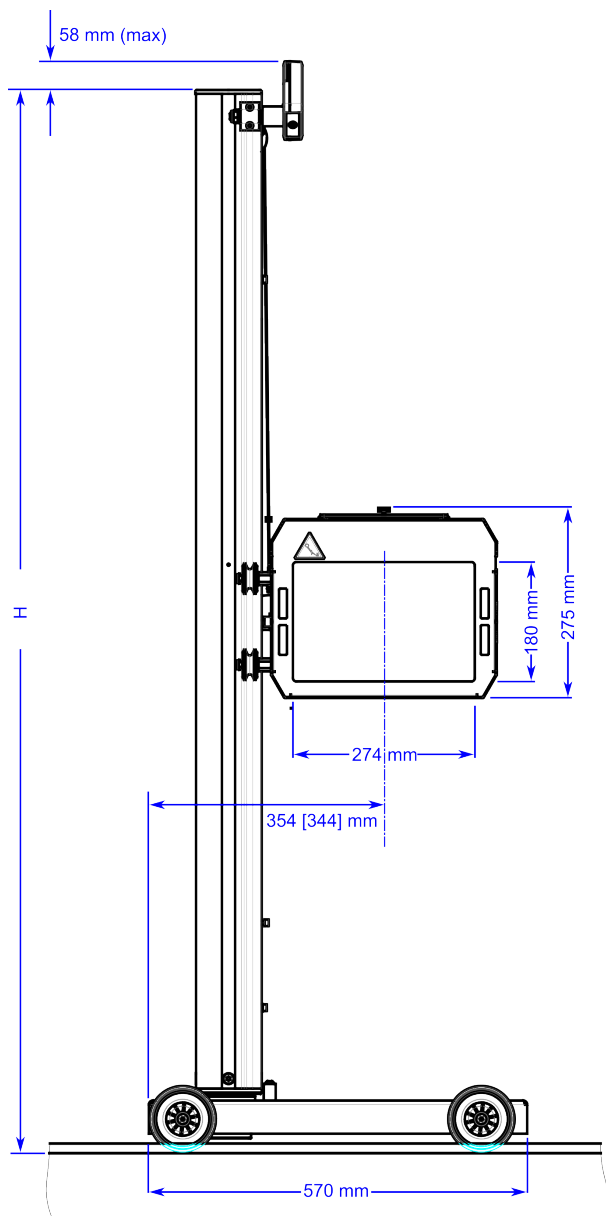

Height of the column (H) from ground level (in mm)	
Standard	Long
1604	1804

Rail tracking distance between axis [T] (mm)
Model 560
567



**Note:** Dimensions between brackets apply to wide-trolley models.

### 5.4.3 SLA 7 NR

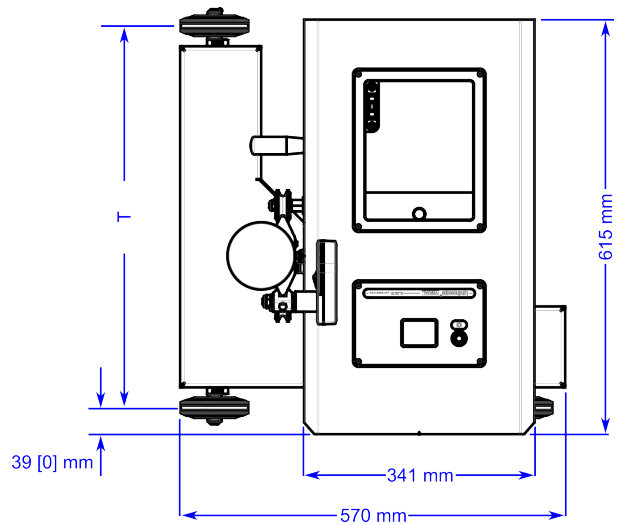
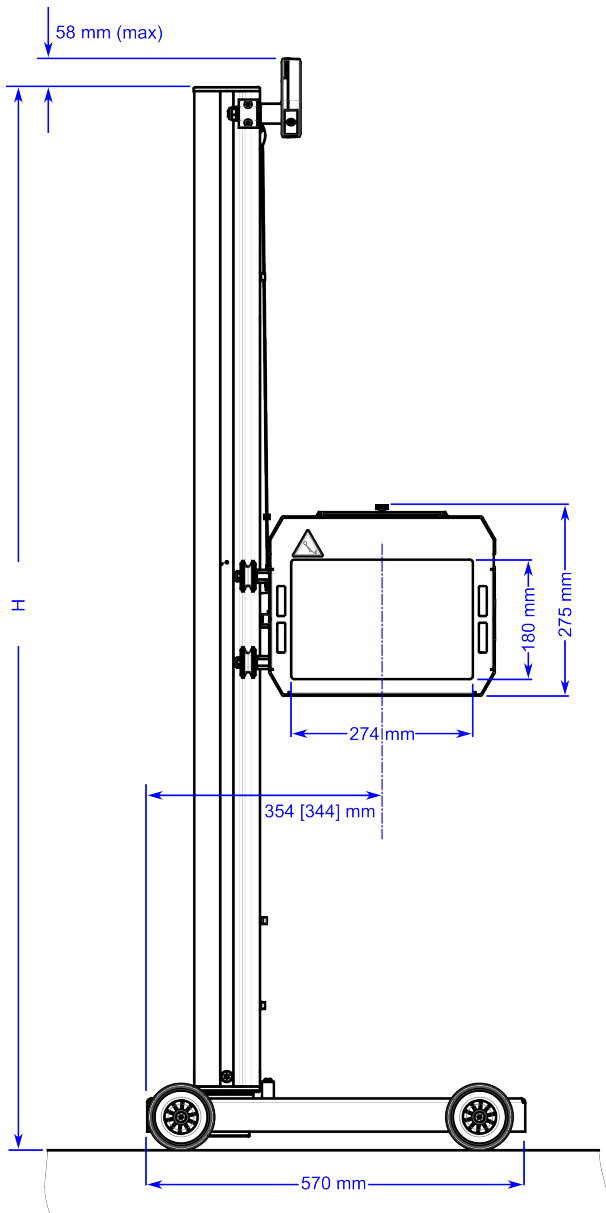

Height of the column (H) from ground level (in mm)	
Standard	Long
1602	1802

Rail tracking distance between axis [T] (mm)
Model 560
567



**Note:** Dimensions between brackets apply to wide-trolley models.

## 5.5 Datasheet

Models	Luminoscope® SLA 7 DR	Double Rail	
	Luminoscope® SLA 7 SR	Single Rail	
	Luminoscope® SLA 7 NR	No Rail	
Headlamp assessment type	Visual		
Testing range	Low beam up	0	%
	Low beam down	-6	%
Luminous intensity digital luxmeter (optional)	0 - 215		kCd
Beam inclination setting (optional)	Rotary knob		
Measurement tolerance	Horizontal	±0.5	%
	Vertical	±0.15	%
	Luminous intensity	±10	%
Measuring distance between headlamp and Luminoscope® lens	200 - 600		mm
Vertical positioning range, measured from lens center to ground. Range may extend slightly further. Depends on rail type and eccentric position.	SLA 7 standard column	≈ 230 - 1300	mm
	SLA 7 long column	≈ 230 - 1500	mm
Distance between tracks	SLA 7 DR / SLA 7 DR-D	394 / 560 / 585 / 660	mm
Device for horizontal alignment	Alignment laser on top of the stand		
Dimensions	See drawings on previous pages.		
Weight	≈ 45		kg
Operating temperature range	Minimum	-10 to +35	°C
Relative humidity	< 80		%
Alignment laser battery	Technology	Alkaline	2x AA
	Voltage	2x 1,5	VDC
	Continuous operating time	8	h
Intensity measurement control panel	Technology	Alkaline	2x AA
	Voltage	2x 1,5	VDC
	Continuous operating time	8	h



---

# 6 Operation

---



The main purpose of the Luminoscope® is to measure specific headlamp beam characteristics such as horizontal beam position, vertical beam position, high beam intensity, etc.

## 6.1 Test cycle references

There is a number of topics related with the test sequence which apply to many of its steps. They are collected below and will be used as a reference along the explanation of the test cycle.

### 6.1.1 Beam icons

Each low beam, high beam and fog beam has its specific beam icon. Next table explains the meaning of the icons.

Icon	Beam
	Low beam
	High beam
	Fog beam

However, the main focus of the SLA 7 is on the low beams.

### 6.1.2 Left / right vehicle side definition

The left and right sides of the vehicle are always defined from the driver's point of view.

Headlamps which are located at the left side (as seen from the driver's point of view) are called the *left headlamps*, and those at the right side are called the *right headlamps*.

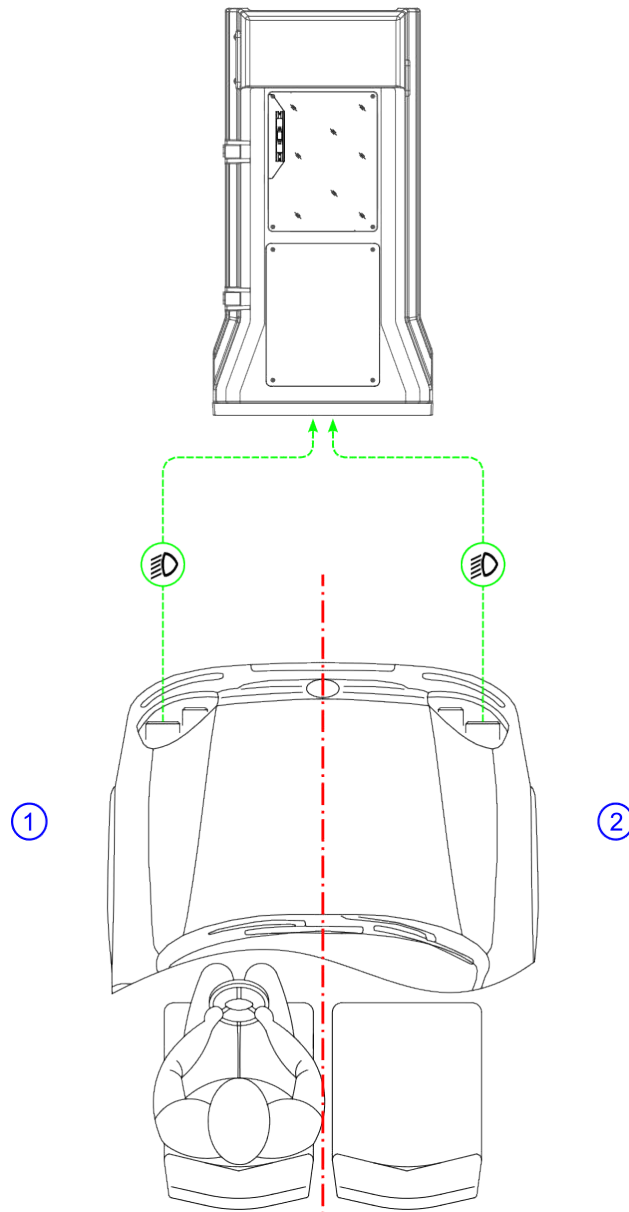

Figure 34: Left / right vehicle side definition

1	Left side of the vehicle	2	Right side of the vehicle
---	--------------------------	---	---------------------------

### 6.1.3 Alignment with the vehicle

Before each test cycle starts, it is necessary to align the optical axis of the headlamp tester with the longitudinal axis or driving direction of the vehicle, in order to minimize the measurement result error in the horizontal direction.

#### 6.1.3.1 Alignment laser

Use the green alignment laser on top of the stand to align the Luminoscope® system with the longitudinal axis of the vehicle.

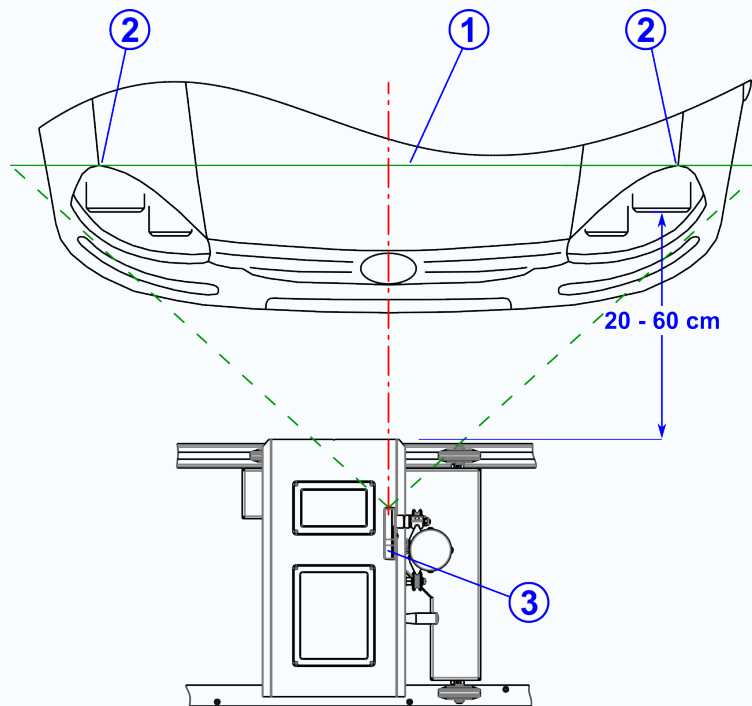

Figure 35: Use of alignment laser to align the Luminoscope® with vehicle longitudinal axis

1. Move the Luminoscope® to the middle of the vehicle. Skip this step for the SLA 7 NR model.



**Attention:** In case of the SLA 7 NR model, the alignment should be performed for each vehicle side separately, i.e. once for the left headlamps and once for the right headlamps.

2. Power the laser **ON** with the corresponding switch. The laser remains powered until it is switched off.
3. Tilt the laser until its beam 1 is projected at the front of the vehicle.



**Attention:** Do not forget to switch the laser **OFF** in order to preserve its batteries' life.

4. Rotate the stand until the laser beam 1 intersects two symmetrical points 2 of the vehicle.

The two symmetrical points should be as far apart as possible, close to the vehicle sides, in order to maximize the precision of the alignment.

Some bodywork colours may cause too much color absorption. In this case, open the front hood and project the laser beam on two symmetrical points at the inside.

### 6.1.4 Positioning in front of the headlamp

It is of great importance that the lens of the Luminoscope® is correctly positioned in front of the headlamp to ensure that as many light rays as possible enter the lens.

This guarantees that the beam image is displayed realistically on the white projection screen inside the Luminoscope® to be able to perform a correct headlamp measurement.

With this purpose, the front of the Luminoscope® has three markings indicating the centre of the lens. This can help the operator to correctly position the lens of the Luminoscope® in front of the headlamp.

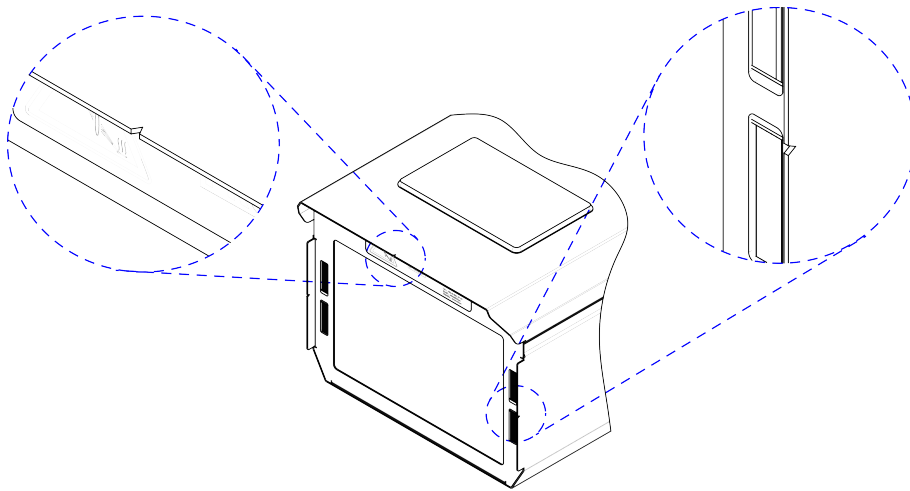

Figure 36: Central markings on the lens front

The operator positions the Luminoscope® in front of the headlamp by moving the optical block vertically and horizontally (without rotating the stand) and by simultaneously looking at the beam projection on the white projection screen inside the optical block. When the beam projection looks as expected, the visual assessment of the beam position can start.

### 6.1.5 Vertical beam target

The headlamp's inclination can be checked by adjusting markings on a vertically movable screen or by comparing its light to fixed markings with known inclination differences.

The Luminoscope® SLA 7 can be supplied equipped for either types of alternative measurements, as explained below.

#### 6.1.5.1 Movable screen. Standard

The movable screen, depicted below, is used to set the vertical inclination of the low beam projection on the projection screen.

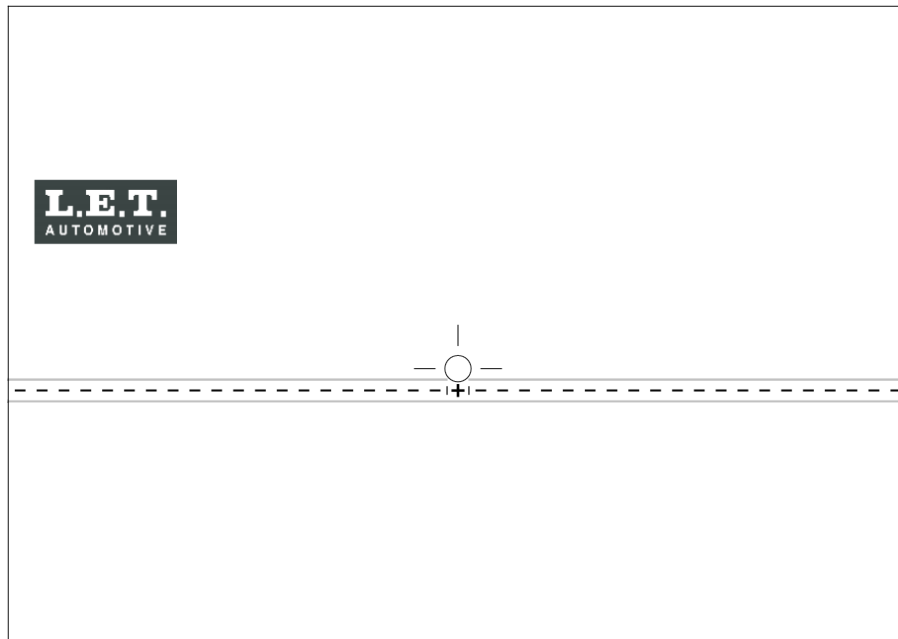

Figure 37: Movable screen

The vertical beam target for the low beams can be set by the rotary inclination knob at the back of the optical block. The value on the knob corresponds with the vertical position of the low beam dashed reference line at the projection screen.



Figure 38: Rotary inclination knob for the low beam inclination

**Remember:** This feature only applies to the low beams. However, the vertical position of the high beam projection and the fog beam projection can also be visually assessed at the projection screen inside the optical block.

#### 6.1.5.2 Fixed screen. UK

SLA 7 units meet UK local regulations and have a fixed screen with markings specified by the DVSA. These units use one of two projection screens, depending on vehicle type, either HGV or non-HGV (MOT).

Inclination is categorized by mounting height:

- Above 850 mm
- Below 850 mm

Luminoscope® for non-HGV testing have a standard screen with four solid red or blue lines marking 0.5%, 1.25%, 2%, and 2.75%.

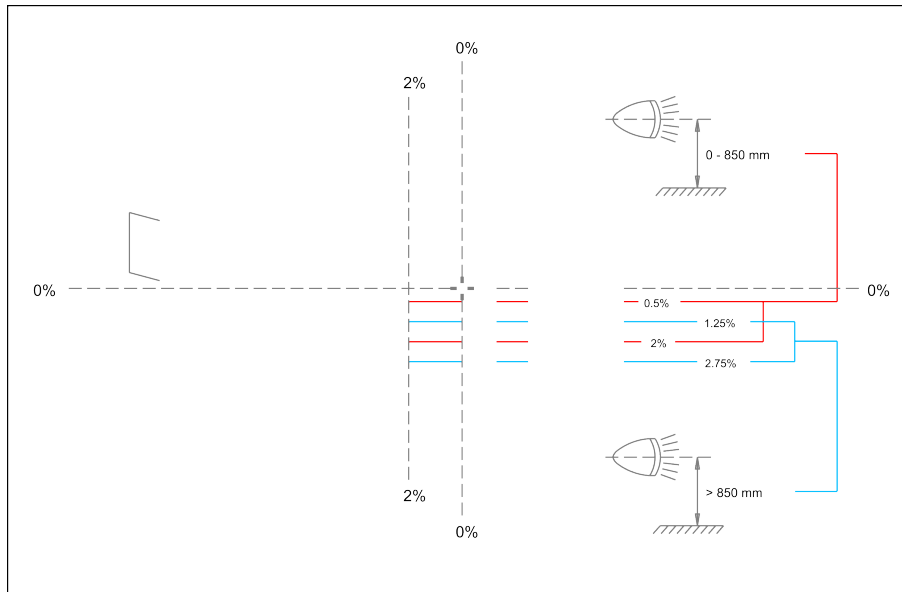

Figure 39: Projection screen for UK for MOT (non-HGV) vehicles

HGV Luminoscope® has an alternative screen with two additional broken lines for 3.25% and 4%, used only for HGVs.

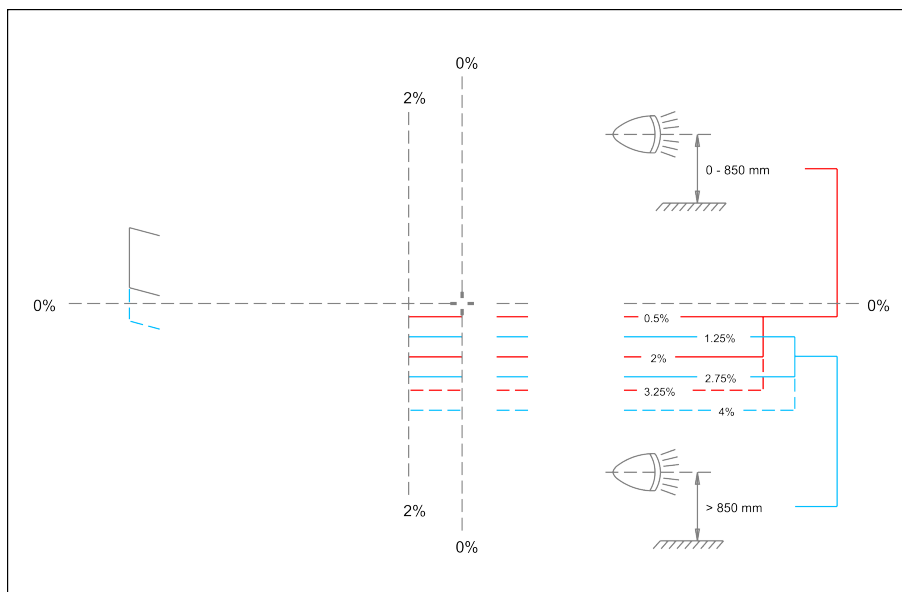

Figure 40: Projection screen for UK for HGV vehicles

## 6.2 Test cycle sequence

This chapter explains the different steps that should be followed in a test cycle.



**Note:** The test cycle could look slightly different depending on the Luminoscope® configuration or step which could be based on different regulations.

Step number	Step description	Comments
1	Alignment with the vehicle	Align the Luminoscope® with the vehicle's driving direction.
2	Positioning in front of the headlamp	Properly position the Luminoscope® in front of the headlamp before starting the measurement.
3	Setting the vertical beam target	Set the vertical beam target value for the low beams by adjusting the rotary inclination knob. This setting depends on the vehicle category, as defined by the local regulations and is not applicable to fixed screen units.
4	Visual headlamp assessment	The projected beam pattern on the white projection screen inside the Luminoscope® is visually assessed against the screen's markings.

### 6.2.1 Alignment with the vehicle

Align the Luminoscope® with the vehicle's driving direction.

Use the green alignment laser on top of the stand to align the Luminoscope® with the longitudinal axis of the vehicle.



**Attention:** In case the Luminoscope® is used on a rail guiding system (e.g. SLA 7 SR – Single Rail or SLA 7 DR – Double Rail), the stand should not be rotated during the cycle, specially when moving the Luminoscope® from one side of the vehicle to the other side.



**Attention:** In case the Luminoscope® is NOT used on a rail guiding system (e.g. SLA 7 NR – No rail), the alignment procedure should be performed separately for each headlamp at the left and right sides of the vehicle.

#### Related information

[Alignment with the vehicle](#) (pg. 48)

### 6.2.2 Setting the vertical beam target



**Attention:** This procedure is not applicable to fixed screen units.

Set the vertical beam target value for the low beams by adjusting the rotary inclination knob. This setting depends on the vehicle category, as defined by the local regulations and is not applicable to fixed screen units.

The vertical beam target value for the low beams should be set by the rotary inclination knob at the rear side of the optical block. The value on the knob corresponds with the vertical position of the low beam reference line at the projection screen.



Figure 41: Rotary inclination knob for the low beam inclination

**Remember:** This feature only applies to the low beams. However, the vertical position of the high beam projection and the fog beam projection can also be visually assessed at the projection screen inside the optical block.

The high beam reference line at the projection screen is positioned 1% (10cm/10m) higher than the low beam reference line.

The fog beam reference line at the projection screen is positioned 1% (10cm/10m) lower than the low beam reference line.

e.g. in case of a rotary knob set at -1%:

- The low beam reference line is positioned at -1%
- The high beam reference line is positioned at 0%
- The fog beam reference line is positioned at -2%

### 6.2.3 Positioning in front of the headlamp

Before the visual headlamp assessment can start, it is required to position the Luminoscope® correctly in front of the headlamp.



**Attention:** A correct positioning of the Luminoscope® in front of the headlamp is necessary for an accurate headlamp measurement.

1. Position the Luminoscope® in front of the headlamp under test.
2. Move the optical block vertically and / or horizontally (without rotating the stand) by simultaneously looking at the beam projection on the white projection screen inside the optical block.
3. Once the beam projection looks as expected (e.g. without beam deformation), the visual assessment can start.

## Related tasks

[Positioning in front of the headlamp](#) (pg. 54)

### 6.2.4 Beam measurement

The beam pattern is projected at the white projection screen inside the Luminoscope® for visual assessment.

If needed, the headlamp can be adjusted to match its beam projection with the reference line(s).

#### 6.2.4.1 Standard movable screen

The beam pattern is projected at the white projection screen inside the Luminoscope® and can be visually assessed.

The beam position should be compared to the corresponding reference line(s) on the screen. If needed the headlamp could be adjusted to match its beam projection with the reference line(s).

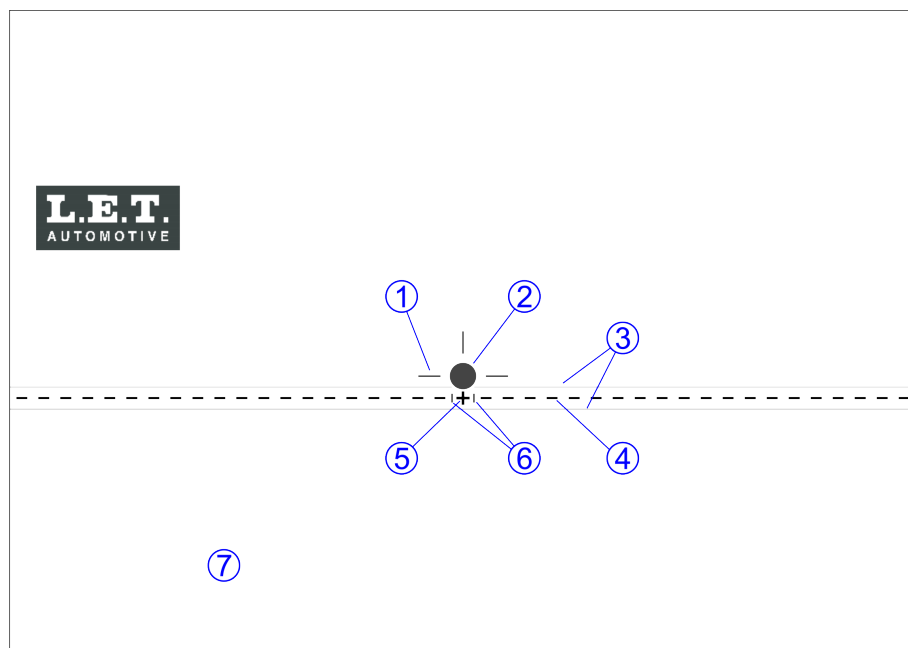

Figure 42: Projection screen with markings

#	Description
1	Reference cross for high beam projection.
2	Geometric center of the screen. The hole is occupied by a light intensity photocell sensor in those units including the optional LIM (Light Intensity Module).
3	Limit lines for the vertical tolerance zone ( $\pm 0.5\%$ ).
4	Reference line, with absolute height corresponding with the knob setting.
5	Horizontal zero to be matched with the V-point of the light projection.
6	Limit lines for the horizontal tolerance zone ( $\pm 0.5\%$ ).
7	Projection screen.

#### 6.2.4.2 Fixed DVSA screen

Visually verify the beam pattern aligns with the screen's reference lines.

Luminoscope® units for the UK market are provided with a fixed screen with an appearance similar to the shown below.

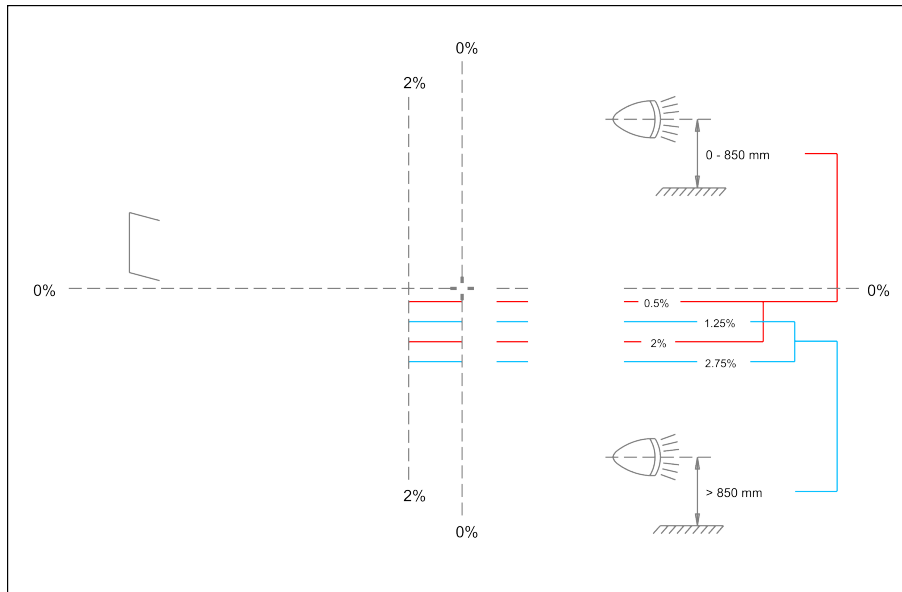

Figure 43: Fixed DVSA projection screen

There are two possible screens depending on the vehicle type, either HGV or non-HGV (MOT). These screen models comply with British Government regulations, that are linked below.

#### European Headlamp Check (Dipped Beam)

European headlamps have either an asymmetric beam with a "kick-up" on the left, or a flat-top beam. They may also have a European approval mark.

To pass:

- The "kick-up" must be visible (unless masked or flat-top beam).
- The cutoff line must be between:
  - 0.5% and 2.75% for headlamps 850 mm or less from the ground.
  - 1.25% and 2.75% for headlamps above 850 mm.
- White light does not show in the zone formed by the 0% vertical and 0.5% horizontal line.

#### British American Headlamp Check (Main Beam)

British American headlamps have an asymmetric main beam with a central "hot spot." They usually have a circular lens marked "1" with a dip arrow.

Fail the headlamp if the "hot spot" is:

- Above the 0% horizontal line
- Below:
  - 2% horizontal (headlamps 850mm or less from ground)
  - 2.75% horizontal (headlamps above 850mm)
- Right of the 0% vertical line
- Left of the 2% vertical line

The brightest part of the beam must move down when dipped.

#### British American Headlamp Check (Dipped Beam)

Check British American headlamps on dipped beam if they have a flat-topped, high-intensity area above and parallel to the 0% horizontal line on the nearside, and/or a circular lens marked "2" (possibly with a dip arrow).

Fail the lamp if the top of the "hot spot" is:

- Above the 0% horizontal line
- Below the 2.75% horizontal line

Fail the lamp if the right edge of the "hot spot" is:

- Right of the 0% vertical line
- Left of the 2% vertical line

**Related information**

[MOT inspection manual: cars and passenger vehicles](#)



# 7 LIM (Light Intensity Module)

The SLA 7 is optionally delivered with a *LIM* (Light Intensity Module) useful for measuring the intensity of the light source.

The optional *LIM* (Light Intensity Module) allows the user to take accurate measurements of the intensity of the light beam hitting the photocell 1 located in the center of the internal projection screen.

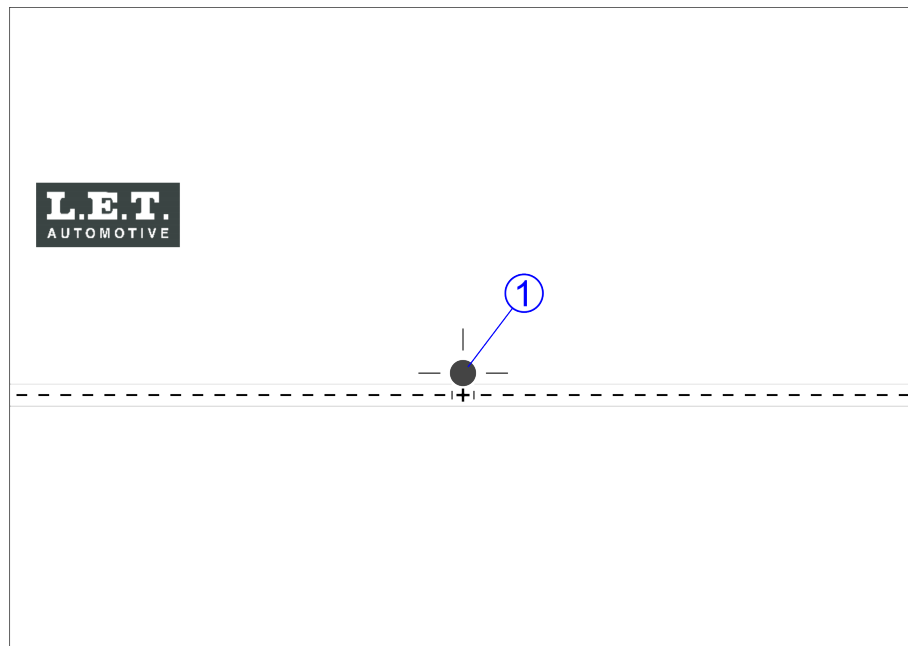

Figure 44: Projection screen with measuring photocell

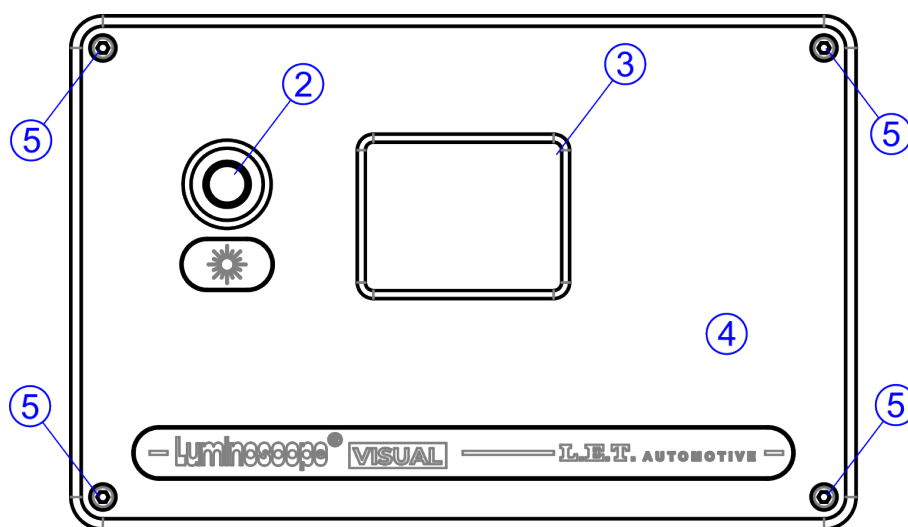

Figure 45: LIM (Light Intensity Module)

#	Part	Description
1	Photocell	Reading the luminous intensity of the headlamp beam.

#	Part	Description
2	Start button	Pressing the button triggers the measuring functionality. A single press starts a dynamic reading, refreshed automatically, which is displayed for a few seconds.  A double press rotates the reading upside-down (180 degrees) for easier reading on any operator's position.  The <i>LIM</i> (Light Intensity Module) shuts down automatically.
3	LCD display	Displays the perceived luminous intensity in kCd as well as other diagnostic messages and batteries' information.
4	Front panel	The front panel covers and protects the electronics and the batteries.
5	Panel retention screws	The front panel has four Allen M3 screws that, once removed, grant access to the batteries for its replacement.

The module is powered by two 1.5V AA alkaline batteries providing the energy for the measurement circuit. The battery compartment is right under the front panel of the module.



